



# **635/636 Series Autoswitch Systems**

**For use with  
Industrial Gases  
in High Flow Applications**

## **INSTALLATION AND OPERATION INSTRUCTIONS**

**Before Installing or Operating, Read and Comply with These Instructions**

Controls Corporation of America  
1501 Harpers Road • Virginia Beach, VA 23454  
To Order Call 1-800-225-0473 or 757-422-8330 • Fax 757-422-3125  
[www.concoa.com](http://www.concoa.com)



## DESCRIPTION OF PRODUCT

The 635/636 Series autoswitches are automatic switchover systems designed to provide a continuous supply of industrial gas. The 636 Series has indicator lights and is capable of interfacing with a Remote Alarm. The 635 Series does not have this feature. These units may be used with one or more cylinders per side. The inlet of the switchover systems are configured with manifold connectors. The system is configured for use with the 528 Series Maniflex system. The standard autoswitch systems will maintain a regulated line pressure within the values shown in the table below:

MODEL	RANGE
636 1XXX	0-15 PSI (1 BAR)
636 2XXX	0-40 PSI (2.8 BAR)
635 3XXX	0-120 PSI (8.4 BAR)
635 1XXX	0-15 PSI (1 BAR)
635 2XXX	0-40 PSI (2.8 BAR)
635 3XXX	0-120 PSI (8.4 BAR)

The inlet pressure must be maintained above 270 PSI (18.9 BAR) for the system to switch between sides properly.

The 636 Series model is designed to be used in conjunction with a Remote Alarm. In addition to a Power Indicator light, the autoswitch is equipped with LED status lights to indicate the condition of the gas cylinders. A green indicator light signifies a "Normal" condition while a red light indicates an "Alarm" (Gas cylinder empty) condition. The autoswitch system includes a separate connector that mates to the connector on the bottom of the unit. This will be needed to construct an interface cable between the Remote Alarm and the autoswitch. Please refer to the ADI Manual that is included with the Remote Alarm for wiring and operating instructions.

**Figure 1 - 636 Series**

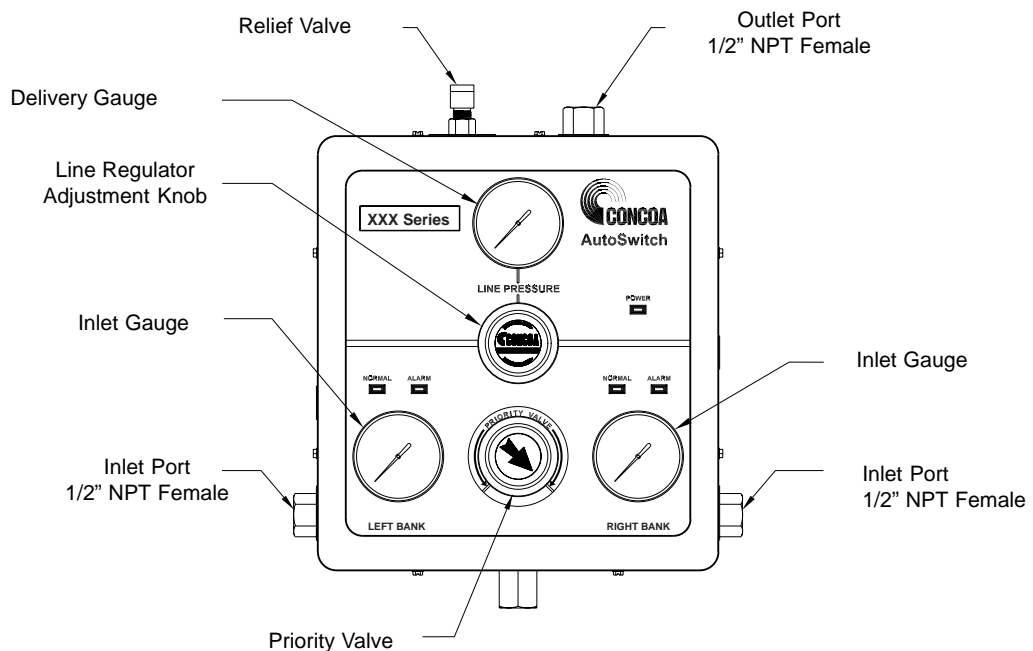

## INTENDED USE OF PRODUCT

The brass 635/636 Series autoswitch systems are intended for use in industrial, non-corrosive gas applications. Please note the safety information shown in the later sections.

## USER RESPONSIBILITY

The User of this equipment should follow all labeling, installation and operation instructions when using this equipment. It is recommended that the user review all safety precautions listed in the safety section of this manual.

Know the properties and special handling requirements of the gas being used. Many gases are dangerous (flammable, toxic, corrosive, etc.) Consult with the cylinder distributor for the proper use of the cylinders and any restrictions in their use. This equipment must be checked periodically. Improperly working equipment should not be used. Broken, worn, distorted, contaminated, or missing components should be replaced by a trained technician immediately.

## CUSTOMER ASSISTANCE

In the event of equipment failure, call the CONCOA Customer Assistance Line: 1-800-225-0473. Please be prepared to provide the model number and serial number of the equipment involved, in addition to some details regarding its application. This would include inlet and outlet pressures, flow rate, environmental conditions, and gas service.

## SAFETY

Carefully read and comply with these instructions before installing or operating any high pressure gas manifold. These manifolds are designed, manufactured, and tested to conform to industry standards for safety for high pressure gas manifolds for maximum inlet pressure of 3000 pounds per square inch (200 bar), working pressure.

Always observe the following safety practices:

- √ Store cylinders with valve caps screwed on, and cylinders chained to a supporting wall or column.
- √ Handle cylinders carefully and only with valve caps screwed on. The cap will prevent the cylinder valve from breaking off at the top of the cylinder if the cylinder is accidentally dropped or falls over. The cap also protects the cylinder valve from damage to screw threads, which could cause leaky connections.
- √ Keep all cylinders away from any source of high temperature (not over 120° F, 50° C) or possible fire hazards. High-pressure gas contained in a closed cylinder becomes increasingly dangerous when exposed to high temperature because pressure increases and the strength of the cylinder decreases.
- √ No smoking should be permitted near oxygen nitrous oxide, flammable gases and flammable mixtures and in area where cylinders are stored.
- √ Where oxygen or nitrous oxide is used, the manifold and cylinders must be kept clean. No oil, grease, or combustible substances should come in contact with oxygen or nitrous oxide storage or handling equipment. Such materials in contact with oxygen or nitrous oxide are readily ignitable and when ignited, will burn intensely.
- √ Never lift gas cylinders with a magnetic lifting device.
- √ Never use an open flame when leak testing.

- √ Always open valves slowly when high-pressure gases are being used. Open valves all the way.
- √ Always be sure that a cylinder contains the correct gas before connecting it to any manifold.
- √ Always leak-test any manifold or distribution pipeline before using.
- √ Always be sure that the gas in a pipeline is the correct gas for the intended use.
- √ Always install a blind gland and nut or piping plug on any manifold inlet fitting if no cylinder is connected to the fitting before opening any cylinder valve which is already connected to the manifold.
- √ Always close all cylinder valves before disconnecting cylinders from a manifold.
- √ Always remove all empty cylinders from a manifold before connecting full cylinders.
- √ Always test cylinders to be sure they are full before connecting to a manifold.
- √ NOTE: Use of Teflon® lined pigtails for oxygen installations is not recommended unless they are equipped with a Distance Volume Piece (DVP). Components in the manifold system can create a dead end passage. The combination of a dead end passage coupled with a rapid pressurization may lead to adiabatic compression of the contained oxygen and subsequent failure of the pigtail by ignition.
- √ All gas distribution piping systems must meet appropriate industrial standards for the intended service, and must be thoroughly cleaned before using.

**Comply with all safety rules and precautions of the following:**

1. American National Standards Institute standard Z49.1 or Safety in Welding and Cutting, American Welding Society, 2501 NW Seventh Street, Miami, FL 33125.
2. N.F.P.A. Standard 51, Oxygen-Fuel Gas Systems for Welding and Cutting, N.F.P.A., 470 Atlantic Avenue, Boston, MA 02210.
3. N.F.P.A. Standard 51B, Cutting and Welding Processes, (see Address in #2)
4. CONCOA Publication ADE 872, Safety Precautions in Welding and Cutting.
5. Local ordinances.
6. O.S.H.A.
7. C.G.A. Pamphlet C-4, American National Standard Method of Marking Portable Compressed Gas Containers to Identify the Material Contained.\*
8. C.G.A. Pamphlet G-4, Oxygen-Information on the properties, manufacture, transportation, storage, handling, and use of oxygen.
9. C.G.A. Pamphlet G-4.1, Equipment Cleaned for Oxygen Service.
10. C.G.A. Pamphlet C-4.4, Industrial Practices for Gaseous Oxygen Transmission and Distribution Piping Systems.
11. C.G.A. Pamphlet G-5, Hydrogen - Information on the properties, manufacture, transportation, storage, handling, and use of hydrogen.
12. C.G.A. Pamphlet G-6, Carbon Dioxide - Information on the properties, manufacture, transportation, storage, handling, and use of carbon dioxide.
13. C.G.A. Pamphlet G-6.1, Standard for Low Pressure Carbon Dioxide Systems at Consumer Sites.
14. C.C.A. pamphlet P-1, safe handling of compressed gases in containers.

## INSTALLATION

The site chosen for the installation of the system shall be level, well ventilated, and at a safe distance from sources of flames, sparks, and excessive heat. The system should not be placed in an area that may subject it to damage from passing trucks, cranes, or other heavy machines. Any oxygen system must not be installed under shafting, belting, or other places where oil can drip on it. Refer to the Manifold ADI for Manifold installation instructions.

- a. Be sure to consider all factors when selecting materials.
- b. Do not use oil or grease on fittings.
- c. Be sure that all fittings are secure and leak tight. Teflon tape should be used on pipe threads. See Figure 6.
- d. Relief valve: The purpose of the relief valve is to protect the autoswitch system and its components only (Figure 2). If there is pressure sensitive equipment downstream of the autoswitch system, it is recommended that an appropriately sized relief valve be installed in the line to protect this equipment.
- e. Purge devices: These devices can be purchased as accessories. Purge devices are used to remove toxic, corrosive, or flammable gases from the customer's system to a safe discharge area. This is particularly helpful when an internal problem occurs (such as regulator malfunction).

**WARNING:** Equipment failure or misuse may lead to problems such as a release of gas through the relief valve or regulator diaphragm. The autoswitch box is not sealed and will leak gas from faulty components. Proper safety measures should be established to handle these and other component failures.

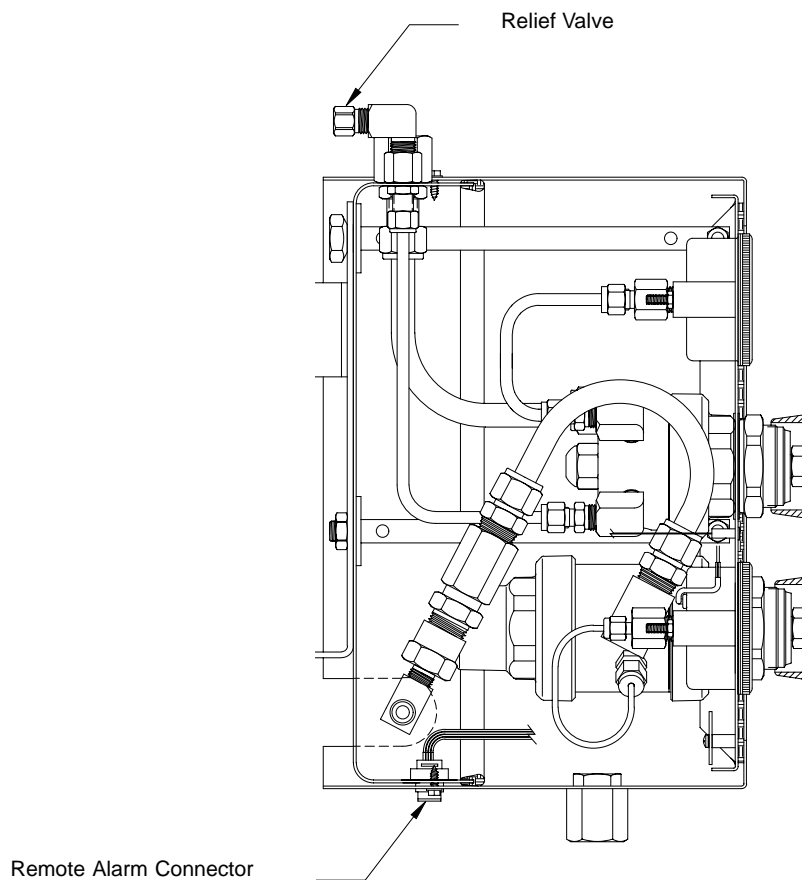
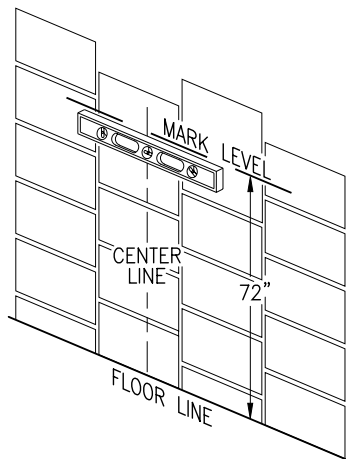

**Figure 2**

## WALL MOUNTING

Follow Compressed Gas Association, OSHA and all applicable local codes. Manifolds should not be placed in locations where the temperature will exceed 102°F (49°C) or fall below 0°F (-18°C). Manifolds installed in open locations should be protected from weather conditions. During winter, protect the manifold from ice and snow. In summer, shade the manifold and cylinders from continuous exposure to direct sunlight. Always leave access to the manifold for cylinder replacement.

1. Determine and mark the vertical center line for installation of the AutoSwitch Console. (Figure 3).
2. Measure from the floor 73" in height\* of this center line. This height will place the manifold header approximately 66" from the floor. Using a level, mark a horizontal line at this point extending approximately 10 inches to the left and right of center.
3. Remove the mounting bracket from the rear of the AutoSwitch Console by removing the retaining nuts at the bottom of the mounting bracket (Figure 5). Place the upper edge of the bracket cross-member on the horizontal line so that it is centered with the vertical line. Holding the bracket with the slotted extensions away from the wall, mark the location of the two mounting bolts (Figure 4)
4. Using appropriate hardware based on wall construction, anchor the mounting bracket to the wall (Figure 4).
5. Place the autoswitch system so that the mounting bracket slots align with the shoulder nuts. With the autoswitch box hanging on the shoulder nuts, align the retaining bolts so that they protrude through the bracket. Replace the mounting nuts that were removed in step 3.



**Figure 3 - Center-line Mark**

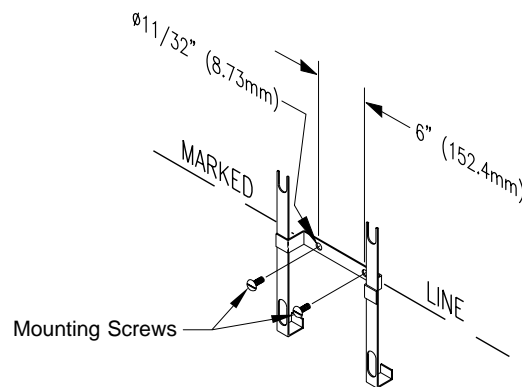

**Figure 4 - Mounting Bracket**

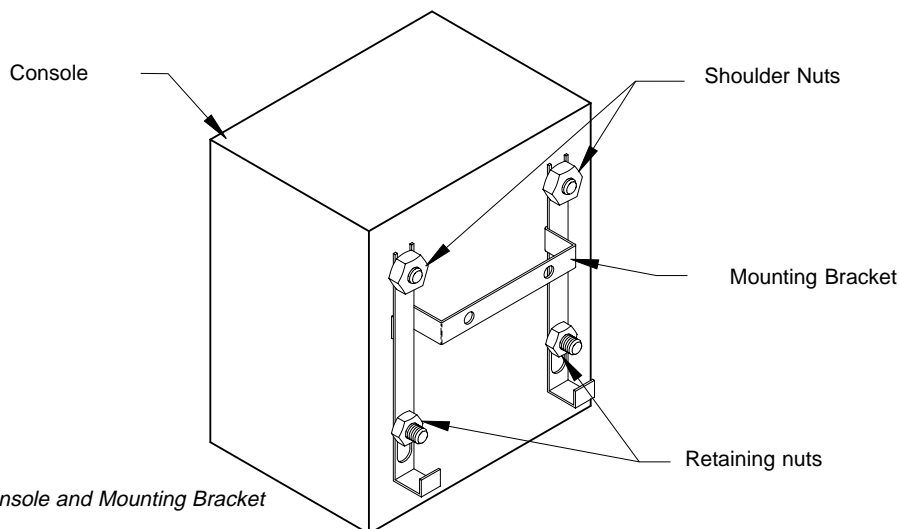

**Figure 5 - Console and Mounting Bracket**

## INLET AND OUTLET CONNECTIONS

### General:

Use an open-end wrench, not a pipe wrench, to install accessories to the autoswitch system. **ALWAYS hold the bulkhead fitting with a wrench when installing the accessories to the autoswitch system. Do not allow the bulkhead fitting to turn; otherwise, connections inside the box may be loosened.** NPT connections require the use of Teflon tape on the threads to make a gas tight seal. (See Figure 6.) On stainless steel connections, the thread sealant helps prevent the connections from galling together when tightening or loosening. CONCOA uses Teflon tape on all of its NPT connections. Follow these rules when using Teflon tape.

Inspect the NPT threads and if necessary, clean the fitting to remove any dirt or thread sealant that remains on the threads. Start the Teflon tape on the second thread as shown in Figure 6; make sure the tape does not overlap the end of the fitting. As the tape is wrapped in the direction of the thread spiral, pull tightly on the end of tape so that the tape conforms to the threads. Wrap the tape around the threads twice. Cut off the excess tape and press the end firmly into the threads.

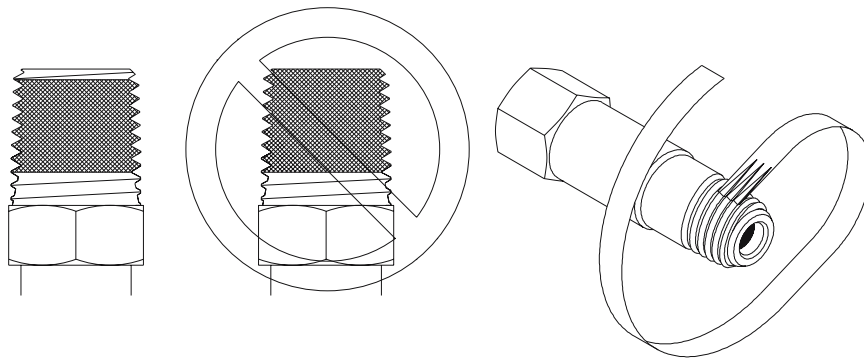
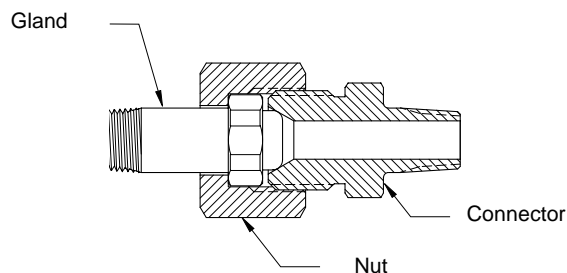

**Figure 6** - Pictorial view of tape seal installation

### Installing the inlet connection:

#### When using a Maniflex system:

The ½ male NPT end of the manifold connector will need to be installed in the inlet port of the autoswitch. The other end of the manifold connector will be connected to the starter block of the 528 series Maniflex system. Please follow the instructions provided with the Maniflex system when connecting and operating the manifold system.



**Figure 7** - Manifold connection

### **Connecting to a cylinder:**

1. Before removing the cylinder cap, move the cylinder of gas to the work site:
  - a. Secure cylinder to the floor, wall, or bench with appropriate chain, strap, or stand to prevent toppling.
  - b. Remove the cylinder cap.
  - c. Be sure the cylinder valve is tightly closed (clockwise)
  - d. Remove the cylinder valve plug, if any.
  - e. Inspect the cylinder valve and threads for damage or contamination.
  
2. Secure the cylinder connection to the cylinder in the following manner:
  - a. Do not force. Tightening the nut onto the cylinder connection should be easy. If it is not, the connection may be wrong for the type of gas being used.
  - b. Left-hand threads are used on some cylinder connections. A notch in the middle of the hex nut typically indicates a left-hand thread.
  - c. Gaskets are used on some inlet connections. Be sure the gasket is in good shape. Do not over-tighten to avoid squashing the gasket into the gas line. Keep extra gaskets on hand.
  - d. Never use oil or grease on regulator or cylinder fittings, as it may contaminate pure gases, or create a fire hazard.

### **Installing the Outlet Connection:**

The autoswitch system has the outlet connection at the top of the box. The connection is a 1/2" NPT Female connection. Connect tubing to the autoswitch that is compatible with the application and is capable of handling the pressure required.

## Pressurizing the system for the first time:

Before system startup, it is recommended that all systems be pressure tested, leak tested, and purged with an inert gas such as nitrogen.

1. Wear safety glasses and gloves.
2. Be sure that both ends of all hoses or pigtails are secured before pressurizing. Turn the line regulator knob counterclockwise until the knob stops turning.
3. When first pressurizing, do not stand in front of or contact the switchover system. Slowly open the cylinder valve. Observe the high pressure gauge for a rise in pressure up to full cylinder pressure.
4. Keep the hand wheel or wrench on the open cylinder valve at all times, to allow prompt emergency shut-off.
5. Inspect all connections for leaks and fix any leaks. A leak detection solution may be applied to the connections (if compatible with the application) which indicates leaks by bubbling. To further check for leaks, or if the leak detection solution can not be used, close the cylinder valve for a period of time (recommended 24 hours), and observe the high pressure gauge for a drop in pressure. If so indicated, recheck the CGA connection and all other high-pressure port connections. Never attempt to fix a leak under pressure. If leaks are detected, depressurize the system and retighten the connection. Begin again at step 3.

**WARNING:** While CONCOA assembles the autoswitch system components to exacting leak-tight standards, the customer should also inspect for any loosening of internal parts that may occur in shipping or installation by completing the pressure decay test detailed above. If all external leaks have been found, corrected, and the system still indicates a leak, disassemble the front cover from the autoswitch after removing the eight screws shown below. Check for leaks on the system's fittings as described above.

6. Slowly turn the line regulator knob clockwise. This will increase the pressure of the line. Adjust to the desired working pressure and again check for leaks using the methods described above.

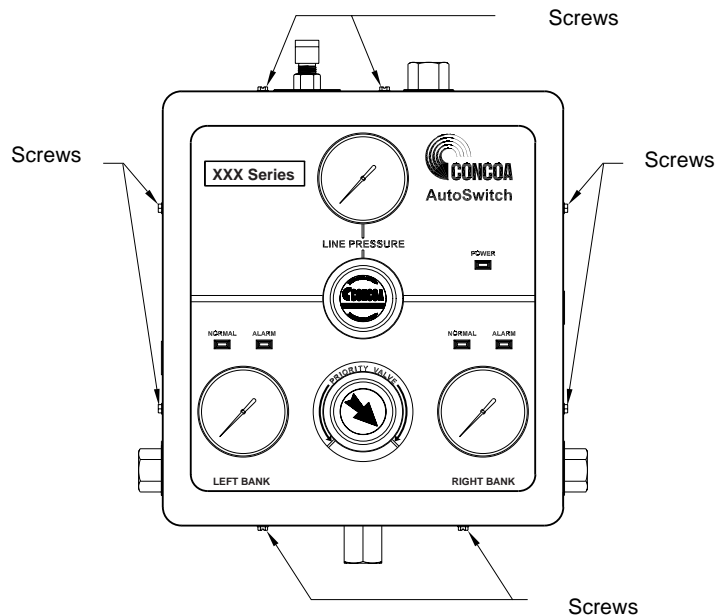

Figure 8

## OPERATION

The arrow on the priority valve always points to the primary side; the bank opposite the primary side is considered the reserve side. Starting with the arrow pointing to the right side, gas will flow from the right side cylinder. As the gas in the primary side is depleted, the gas pressure will drop on the right gauge. When the inlet pressure drops to the pressure setting of the reserve side regulator, flow will begin from the reserve cylinder; the inlet pressure on the primary side will also stabilize. This is called a changeover. At this point, the gas pressure on the reserve side (preset regulator) will drop. This indicates that its time to change the cylinders on the primary side. Before removing the nearly depleted primary cylinder, the priority valve should be rotated 270°. This makes the reserve cylinder, the primary source. Remove the depleted cylinder and replace with a full cylinder. Before removing the cylinder be sure to close the cylinder valve and any other valves that connect the cylinder to the system. The full, replacement cylinder is now the reserve cylinder. Note: while changing cylinders on one side, there will be no interruption in flow. A depleted cylinder will have the following gas pressure remaining:

MODEL	RANGE
636 1XXX	270 PSI (19 BAR)
636 2XXX	270 PSI (19 BAR)
635 3XXX	270 PSI (19 BAR)
635 1XXX	270 PSI (19 BAR)
635 2XXX	270 PSI (19 BAR)
635 3XXX	270 PSI (19 BAR)

Gas will continue to flow from the primary side until the outlet pressure of the preset regulator matches the pressure of the priority valve regulator. (The pressure setting of the priority valve regulator changes when the knob is turned 270°). When the gas pressure stops dropping on the preset regulator and starts to drop on the priority valve regulator, it is time to change the left cylinder. The knob is rotated 270° to the right before the left cylinder is changed. It is helpful to maintain a log of cylinder pressure, noting which direction the arrow is pointing on the priority valve. When the pressure gauge is very low and the reserve side indicates that gas has begun to flow from the reserve cylinder, it is time to rotate the knob and attach a full cylinder in reserve.

If the knob is not rotated before the empty cylinder is changed, two things can happen. First, gas may flow from the changed cylinder to the existing cylinder. This is because the pressure setting of the regulator on the primary side allows the regulator main valve to remain open. Second, when the cylinder is changed, gas will begin to flow from the new cylinder, stopping flow from the existing cylinder. This means the existing cylinder may be partially empty. After several cycles, it is possible that the reserve cylinder may empty shortly after a switchover occurs. Always remember to rotate the knob on the priority valve regulator **before** changing a depleted cylinder.

Adjusting the alarm set point, does not affect the switchover point of the autoswitch. The alarm is used to provide an audible and visual warning that a changeover is about to occur. If the nearly depleted cylinders are changed when the alarm LED's illuminate, the cylinders will not be as empty as if the actual changeover had occurred. Slide the red tab seen on the inlet gauge to adjust the alarm set point. The lowering of the alarm set point pressure may cause the alarm not to work properly. When adjustments are made, check the function of the system. With the knob arrow turned fully clockwise, pressurize the system and shut off the inlet pressure to both sides. Allow the inlet pressure on the right side to decrease by allowing a small flow (50 CFH). Observe both inlet gauges. When the right bank is low (below the set point on the gauge), the red LED will illuminate. Make sure the red LED illuminates before the pressure on the opposite side starts to decrease. Re-pressurize system and check the opposite side of the system in the same manner (the knob arrow must be turned fully counter-clockwise).

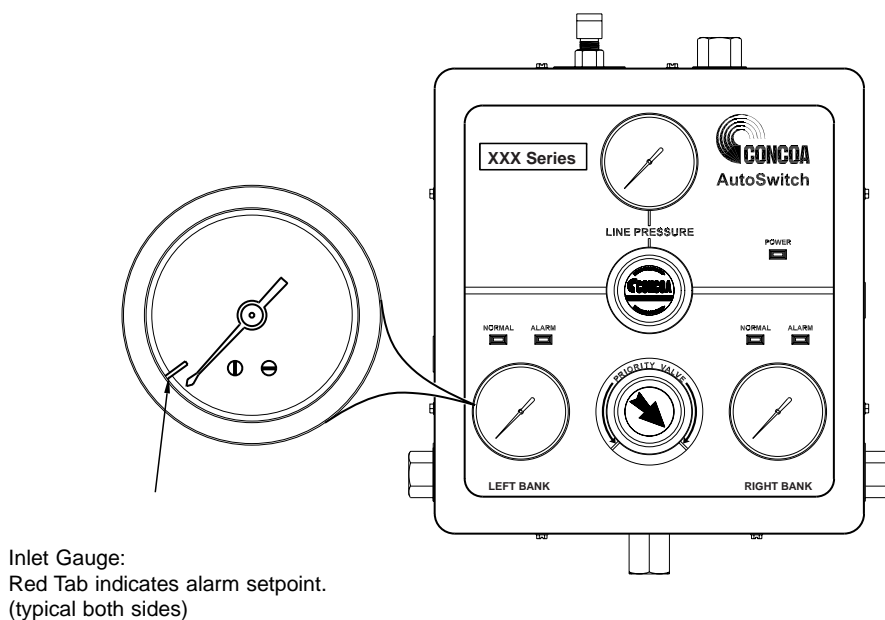

**Figure 9**

## MAINTAINENCE

On regular intervals, the system should be checked for leaks and proper function (see trouble shooting). Any leaks in the system should be corrected immediately. The pigtail check valve should also be checked for leaks when a depleted cylinder is removed. Note: the system inlet and pigtail should be pressurized when checking for leaks. At no time should the preset regulator's or priority valve regulator's pressure settings be changed.

## TROUBLESHOOTING

Symptom	Cause
<ol style="list-style-type: none"> <li>1. Gas leakage at the line regulator outlet when the adjusting knob of the line regulator is completely backed out.</li> <li>2. With no flow through the system (downstream valves closed and adjusting screw in) line pressure steadily increases above set pressure.</li> <li>3. Gas leakage from spring case (adjusting screw/knob end of regulator).</li> <li>4. Gas leakage from any joint.</li> <li>5. Excessive drop in working pressure with regulator flowing gas.</li> <li>6. Gas leakage from relief valve.</li> <li>7. Gas leakage from any gauge</li> <li>8. Gauge does not return to zero when not under gas pressure</li> <li>9. Gauge does not consistently repeat the same reading.</li> <li>10. The system makes a noise or hums.</li> </ol>	<p>Regulator(s) have malfunctioned. Replace or repair</p>
<ol style="list-style-type: none"> <li>1. Switchover system seems to be using gas from the primary <b>and</b> reserve cylinders (pressure is decreasing on both inlet gauges at the same time)</li> </ol>	<ol style="list-style-type: none"> <li>1. Make sure the priority valve knob is turned fully to the right or left.</li> <li>2. Observe the inlet pressure. It may be necessary to do this during times of the heaviest use. If the inlet pressure is <u>less</u> than the values listed below, replace the high-pressure cylinders.</li> </ol> <p style="margin-left: 40px;">           635 1XXX 270 PSI (19 BAR)            635 2XXX 270 PSI (19 BAR)            635 3XXX 270 PSI (19 BAR)            636 1XXX 270 PSI (19 BAR)            636 2XXX 270 PSI (19 BAR)            636 3XXX 270 PSI (19 BAR)         </p> <p style="margin-left: 40px;">           If liquid cylinders are used and the inlet pressure increases significantly when the system is not in use, then the system is over-withdrawing the liquid cylinders. Additional capacity may be added to the system to prevent this.         </p>
<ol style="list-style-type: none"> <li>1. Inlet Gauges not reading pressure</li> </ol>	<ol style="list-style-type: none"> <li>1. Check that the valves on the cylinders are opened.</li> <li>2. If using a manifold system, check that the valve on the manifold is opened.</li> </ol>
<ol style="list-style-type: none"> <li>1. Power light is not on.</li> </ol>	<ol style="list-style-type: none"> <li>1. Check that connector to remote alarm is properly plugged into the autoswitch and the alarm.</li> <li>2. Check that the remote alarm is powered on.</li> <li>3. Check that cable between autoswitch and remote alarm is wired correctly.</li> </ol>

## TROUBLESHOOTING (cont.)

Symptom	Cause
1. Status lights are not lighted	<ol style="list-style-type: none"> <li>1. Check that connector to remote alarm is properly plugged into the autoswitch and the alarm.</li> <li>2. Check that the remote alarm is powered on.</li> <li>3. Check that cable between autoswitch and remote alarm is wired correctly</li> </ol>
<ol style="list-style-type: none"> <li>1. Green status light(s) are lighted when the pressure is below the set point on the gauges</li> <li>2. Red status light(s) are lighted when the pressure is above the set point on the gauges</li> </ol>	<ol style="list-style-type: none"> <li>1. Cable to remote alarm wired incorrectly. Follow instructions in remote alarm ADI to correct problem.</li> </ol>
1. With full tank pressure, red alarm light(s) are on.	<ol style="list-style-type: none"> <li>1. Check that the setpoint on the gauges is set properly</li> </ol>

## SERVICE

A Unit that is not functioning properly should not be used and should be returned to CONCOA for service. A Return Material Authorization (RMA) number must be issued for any product returned to CONCOA for service. Please contact a Customer Service Representative at 1-800-225-0473 to receive this number. You will be asked to provide:

1. Model Number
2. Gas Service
3. Inlet pressure and type of gas supply
4. Outlet pressure
5. Approximate gas usage.

When shipping product back to CONCOA for repair the following steps should be followed:

1. Package the product sufficiently to prevent damage. If possible return product in its original packing.
2. Include RMA number on the outside of the carton.
3. Ship prepaid.
4. Include a written description of the problem you encountered with the product inside the package.
5. Include a statement of the gas service the product was used in.
6. Purge all equipment before shipping to protect the transporter and service personnel. Purging is especially important if the equipment has been in hazardous or corrosive gas service.

## Warranty Information

This equipment is sold by CONTROLS CORPORATION OF AMERICA under the warranties set forth in the following paragraphs. Such warranties are extended only with respect to the purchase of this equipment directly from CONTROLS CORPORATION OF AMERICA or its Authorized Distributors as new merchandise and are extended to the first Buyer thereof other than for the purpose of resale.

For a period of one (1) year from the date of original delivery (90 days in corrosive service) to Buyer or to Buyer's order, this equipment is warranted to be free from functional defects in materials and workmanship and to conform to the description of this equipment contained in this manual and any accompanying labels and/or inserts, provided that the same is properly operated under conditions of normal use and that regular periodic maintenance and service is performed or replacements made in accordance with the instructions provided. The foregoing warranties shall not apply if the equipment has been repaired: other than by CONTROLS CORPORATION OF AMERICA or a designated service facility or in accordance with written instructions provided by CONTROLS CORPORATION OF AMERICA, or altered by anyone other than CONTROLS CORPORATION OF AMERICA, or if the equipment has been subject to abuse, misuse, negligence or accident.

CONTROLS CORPORATION OF AMERICA's sole and exclusive obligation and Buyer's sole and exclusive remedy under the above warranties is limited to repairing or replacing, free of charge, at CONTROLS CORPORATION OF AMERICA's option, the equipment or part, which is reported to its Authorized Distributor from whom purchased, and which if so advised, is returned with a statement of the observed deficiency, and proof of purchase of equipment or part not later than seven (7) days after the expiration date of the applicable warranty, to the nearest designated service facility during normal business hours, transportation charges prepaid, and which upon examination, is found not to comply with the above warranties. Return trip transportation charges for the equipment or part shall be paid by Buyer.

**CONTROLS CORPORATION OF AMERICA SHALL NOT BE OTHERWISE LIABLE FOR ANY DAMAGES INCLUDING BUT NOT LIMITED TO: INCIDENTAL DAMAGES, CONSEQUENTIAL DAMAGES, OR SPECIAL DAMAGES, WHETHER SUCH DAMAGES RESULT FROM NEGLIGENCE, BREACH OF WARRANTY OR OTHERWISE.**

**THERE ARE NO EXPRESS OR IMPLIED WARRANTIES WHICH EXTEND BEYOND THE WARRANTIES HEREINABOVE SET FORTH. CONTROLS CORPORATION OF AMERICA MAKES NO WARRANTY OF MERCHANTABILITY OR FITNESS FOR A PARTICULAR PURPOSE WITH RESPECT TO THE EQUIPMENT OR PARTS THEREOF.**

Controls Corporation of America  
1501 Harpers Road • Virginia Beach, VA 23454  
To Order Call 1-800-225-0473 or 757-422-8330 • Fax 757-422-3125  
[www.concoa.com](http://www.concoa.com)