



Protocol Switchover Station

INSTALLATION AND OPERATION INSTRUCTIONS

Before Installing or Operating, Read and Comply with These Instructions

Controls Corporation of America
1501 Harpers Road Virginia Beach, VA 23454
To Order Call 1-800-225-0473 or 757-422-8330 • Fax 757-422-3125
www.concoa.com

March 2003
February 2003

THIS PAGE INTENTIONALLY LEFT BLANK

DESCRIPTION OF PRODUCT

The Protocol Switchover Station is a wall mounted manual switchover system for the connection of two cylinders to a regulator such that one cylinder can be in service and the second cylinder is held in reserve. Further there is a valve to shut-off the flow from either cylinder to allow the safe changing of a cylinder while the system is in service. The Protocol Switchover Station with Alarm is equipped with a pressure switch gauge that closes on declining pressure to activate the 5265134-01-120 (120 VAC) or 5295134-01-220 (220 VAC) alarm system indicating that the gas cylinder in use is running low on gas.

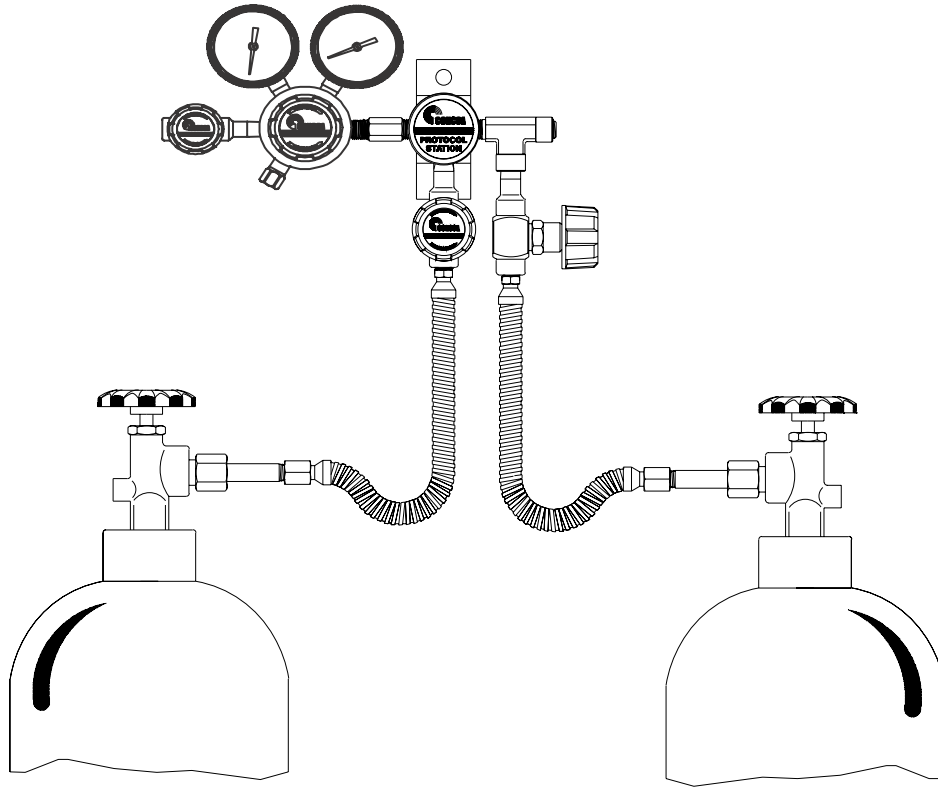

Figure 1

USER RESPONSIBILITY

This equipment will perform in conformity with the description contained in this manual and accompanying labels and/or inserts when installed, operated, maintained, and repaired in accordance with the instructions provided. This equipment must be checked periodically for leaks and functionality. Equipment that is not working properly should not be used. Parts that are broken, missing, worn, or distorted should be replaced immediately. CONCOA recommends that a telephone or written request for service advice be made to CONCOA Customer Service in Virginia Beach, Virginia, PHONE: 1-800-225-0473, FAX: 1-757-422-3125, or E-MAIL: e-mail@concoa.com.

This equipment or any of its parts should not be altered without prior written approval by CONCOA. The user of this equipment shall have the sole responsibility for any malfunction that results from improper use, faulty maintenance, damage, improper repair, or alteration by anyone other than CONCOA or a service facility designated by CONCOA.

CUSTOMER ASSISTANCE

In the event of equipment failure, call the CONCOA Customer Assistance Line: 1-800-225-0473. Please be prepared to provide the model number and serial number of the equipment involved, in addition to some details regarding its application. This would include inlet and outlet pressures, flow rate, environmental conditions, and gas service.

Things to consider before removing the system from the box:

1. Know the properties and special handling requirements of the gas being used. Many specialty gases are quite dangerous (flammable, toxic, corrosive, simple asphyxiant, or oxidizers). Equipment failure or misuse may lead to the sudden release of service gas into the surrounding area. Proper safety measures should be established to handle these and other component failures.
2. Be sure that the assembly purchased is suitable for the gas and type of service intended. The label provides the following information:
 - a. Model number
 - b. Serial number
3. Be sure that the equipment received conforms to the order specifications. The user is responsible for selecting equipment compatible with the gas in use, and conditions of pressure, temperature, flow, etc.
4. Selection information can be found in CONCOA technical data sheets. In addition, CONCOA representatives are trained to aid in the selection process.
5. Inspect the assembly upon receipt to be sure that there is no damage or contamination. Pay particular attention to connecting threads. While CONCOA assembles system components to exacting leak-tight standards, the customer should also inspect for any loosening of parts that may occur in shipping or installation. Loose parts may be dangerously propelled from an assembly. If there are adverse signs (leakage or other malfunction), return the assembly to the supplier. While it is advised that soiled components be returned for cleaning, simple external dust or grease may be removed by a clean cloth and if required with aqueous detergent suitable for the application. If there are signs of internal contamination, return to the supplier.

GENERAL SAFETY PRACTICES

1. Before system startup, it is recommended that all systems be pressure tested, leak tested, and purged with an inert gas such as nitrogen. To accomplish this with connections other than a CGA 580, it will be necessary to use an adapter. The recommended use of an adapter is for temporary use, for start-up and system checks only. Adapters should never be used on a permanent basis.
2. Comply with precautions listed in C.G.A. Pamphlet P-1, Safe Handling of Compressed Gases in Containers.
3. Consult the cylinder distributor for the proper use of cylinders and for any restrictions on their use (such as flow rate and temperature requirements).
4. Store cylinders with valve caps screwed on, and cylinders chained to a supporting wall or column. Handle cylinders carefully and only with valve caps screwed on. The cap will reduce the chance that the cylinder valve will break off if the cylinder is accidentally dropped or falls over. The cap also protects the cylinder valve from damage to screw threads, which could cause leaky connections.
5. All manifolds used with flammable gases should be provided with approved flashback arrestors to stop any burning gas in the pipeline from getting back to the manifold or cylinders.
6. No smoking should be permitted near oxygen, nitrous oxide, any other oxidizer, flammable gases, or flammable mixtures, or in areas where cylinders are stored..
7. Where oxygen or nitrous oxide is used, the manifold and cylinders must be kept clean. No oil, grease, or combustible substances should come in contact with oxygen or nitrous oxide storage or handling equipment. Such materials in contact with oxygen or nitrous oxide are readily ignitable and when ignited, will burn intensely.
8. Never use an open flame when leak testing.
9. Always open valves slowly when high-pressure gases are being used.
10. Always be sure that a cylinder contains the correct gas before connecting it to any manifold.

11. Always leak-test any manifold or distribution pipeline before using.
12. Always be sure that the gas in a pipeline is the correct gas for the intended use.
13. Always close all cylinder valves before disconnecting cylinders from a manifold.
14. Always remove all empty cylinders from a manifold before connecting full cylinders.
15. Always test cylinders to be sure the cylinders are full before connecting to a manifold.

All gas distribution piping systems must meet the appropriate industrial standards for the intended service and must be thoroughly cleaned before using. For the United States, some applicable safety rules and precautions are listed below:

1. American National Standards Institute standard Z49.1 or Safety in Welding and Cutting, American Welding Society, 2501 NW Seventh Street, Miami, FL 33125.
2. N.F.P.A. Standard 51, Oxygen-Fuel Gas Systems for Welding and Cutting, N.F.P.A., 470 Atlantic Avenue, Boston, MA 02210.
3. N.F.P.A. Standard 51B, Cutting and Welding Processes, (see Address in #2)
4. CONCOA Publication ADE 872, Safety Precautions in Welding and Cutting.
5. Local ordinances.
6. O.S.H.A.
7. C.G.A. Pamphlet C-4, American National Standard Method of Marking Portable Compressed Gas Containers to Identify the Material Contained.*
8. C.G.A. Pamphlet G-4, Oxygen-Information on the properties, manufacture, transportation, storage, handling, and use of oxygen.
9. C.G.A. Pamphlet G-4.1, Equipment Cleaned for Oxygen Service.
10. C.G.A. Pamphlet C-4.4, Industrial Practices for Gaseous Oxygen Transmission and Distribution Piping Systems.
11. C.G.A. Pamphlet G-5, Hydrogen - Information on the properties, manufacture, transportation, storage, handling, and use of hydrogen.
12. C.G.A. Pamphlet G-6, Carbon Dioxide - Information on the properties, manufacture, transportation, storage, handling, and use of carbon dioxide.
13. C.G.A. Pamphlet G-6.1, Standard for Low Pressure Carbon Dioxide Systems at Consumer Sites.
14. C.C.A. Pamphlet P-1, safe handling of compressed gases in containers.
15. C.G.A. Safety Bulletin SB-2, Oxygen Deficient Atmospheres.

*C.G.A. pamphlets can be obtained from the Compressed Gas Association, 1235 Jefferson Davis Highway, Arlington, VA 22202-3239, (703) 979-0900. Publications: (703) 979-4341. Fax: (703) 979-0134.

INSTALLATION

1. The Protocol Switchover Station shall be securely fastened to a wall using fasteners appropriate for the wall construction. Mounting dimensions are provided in Figure 2 and 3.

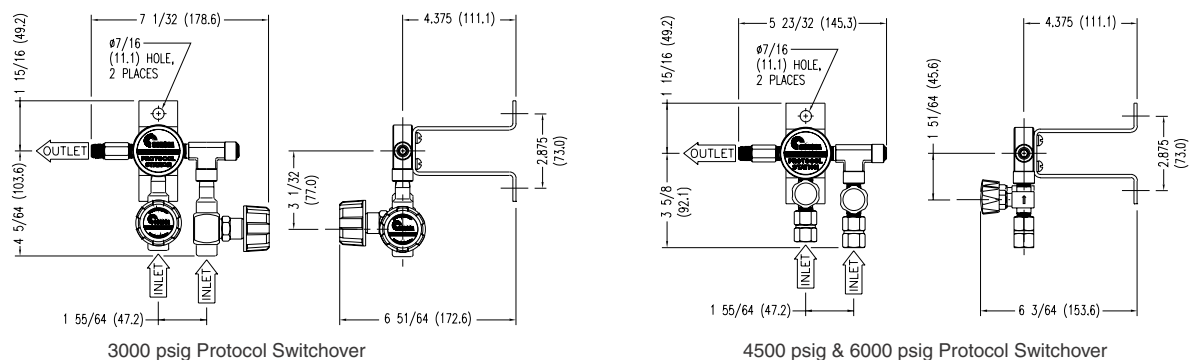

Figure 2 - Protocol Switchover Station

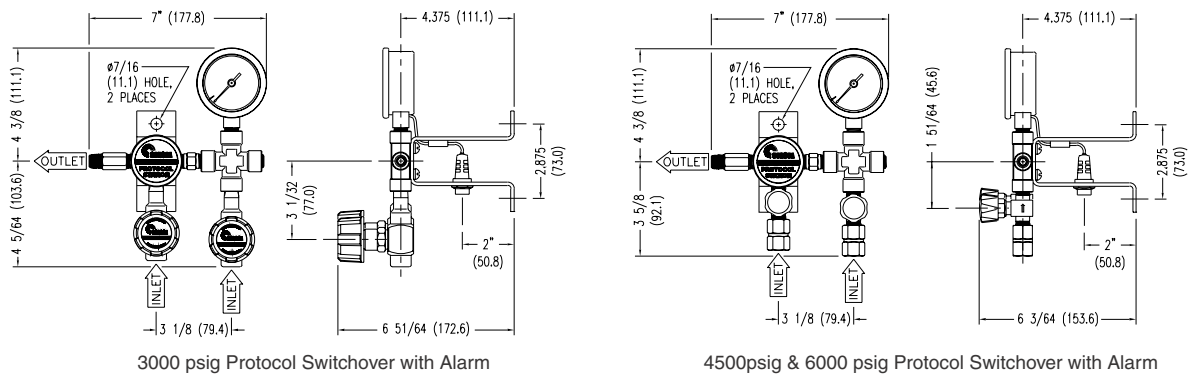

Figure 3 - Protocol Switchover with Alarm

2. If not already installed, the pigtail provided shall be threaded into the inlet connection on the diaphragm valves as described in the section “Installing Pipe Thread Connections”.
3. If you have a Protocol Switchover with Alarm, refer to the instructions provided with the 5295134-01-120 or 220 for wiring instructions.
4. For systems with pressure switch and remote alarm, the alarm setting is accomplished by removing the bezel and lens on the pressure switch gauge and moving the red wire indicator to the desired pressure setting.
5. Before operating the regulator, read and understand ADI-2068, Regulator Installation.

WARNING: Equipment failure or misuse may lead to problems such as a release of gas through the relief valve or regulator diaphragm. The autoswitch box is not sealed and will leak gas from faulty components. Proper safety measures should be established to handle these and other component failures.

Installing Pipe Thread Connections:

Use an open-end wrench, not a pipe wrench, to install accessories to the system. The NPT connections require the use of Teflon tape on the threads to make a gas tight seal. On stainless steel connections, the Teflon tape helps prevent the connections from galling together when tightening or loosening. Follow these rules when using Teflon tape.

Taping procedure:

Before applying Teflon tape, inspect the NPT threads and if necessary, clean the fitting to remove any dirt or thread sealant that remains on the threads. Start the Teflon tape on the second thread as shown above; make sure the tape does not overlap the end of the fitting. As the tape is wrapped in the direction of the thread spiral, pull tightly on the end of tape so that the tape conforms to the threads. Apply two overlapping layers of Teflon tape. Cut off the excess tape and press the end firmly into the threads.

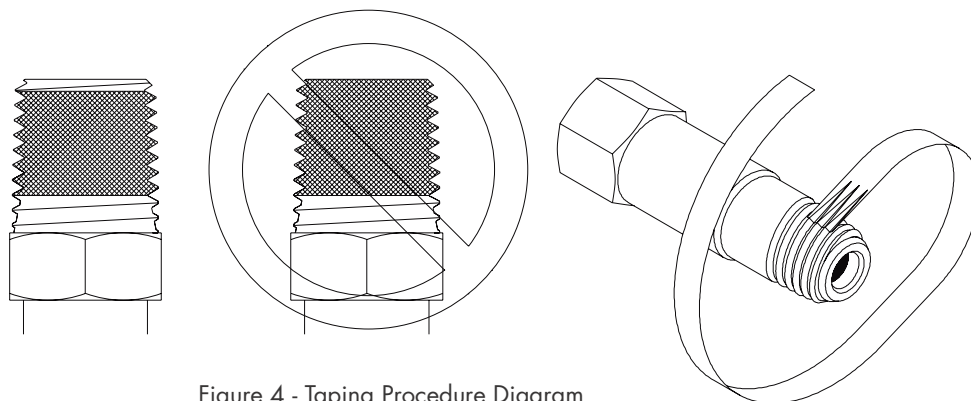
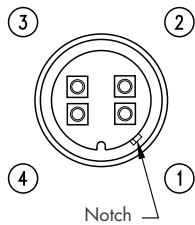
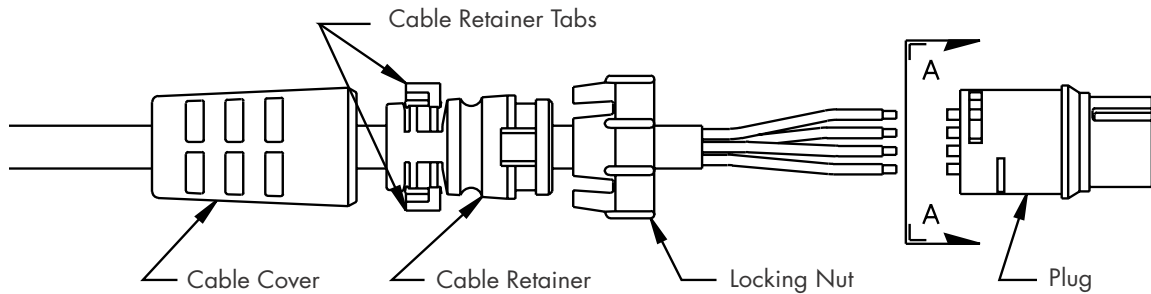

Figure 4 - Taping Procedure Diagram

OPTIONAL PRESSURE SWITCH WIRING DETAILS

CONCOA Protocol Stations are optionally provided with pressure switch inlet gauges for use with CONCOA Remote Alarm Systems or other compatible devices. The Protocol Stations marked with 'Normally Open' near the wiring connector utilize Normally Open pressure switch gauges. The switch in the gauge is closed above the set point, allowing current flow. The switch opens on declining pressure at the set point, opening the circuit. Any time the pointer is below the red tab, the electrical switch is open. The wiring connector pin connections are detailed below:



PROTOCOL STATION	PROTOCOL STATION CONNECTOR PIN #
CYLINDER STATUS	3
+12V DC	1
GROUND	4

The pressure switch gauges have a red indicator tab located on the outside edge of the gauge dial face (see illustration below). The pressure switch setting provides a contact to an external device that indicates low cylinder pressure whenever the gauge pointer is below the red tab indicator.

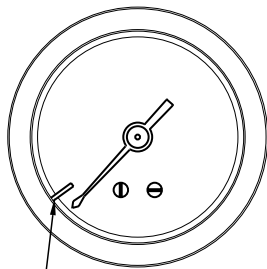

Inlet Gauge: Red Tab Indicates Pressure Switch Setpoint

MAX POWER 10W, 10VA
 SWITCHING CURRENT - 0.5 AMPS
 (NON-INDUCTIVE)

OPERATION

Connecting to a cylinder:

1. Before removing the cylinder caps, move the cylinders of gas to the work site:
 - a. Secure cylinders to the floor, wall, or bench with appropriate chain, strap, or stand to prevent toppling. CONCOA part number 5181611 or 518 1612 cylinder wall brackets are appropriate.
 - b. Remove the cylinder caps.
 - c. Be sure the cylinder valves are tightly closed (clockwise)
 - d. Remove the cylinder valve plugs, if any.
 - e. Inspect the cylinder valves and threads for damage or contamination.

2. Secure the cylinder connections to the cylinder in the following manner:
 - a. Do not force. Tightening the nut onto the cylinder connection should be easy. If it is not, the connection may be wrong for the type of gas being used.
 - b. Left-hand threads are used on some cylinder connections. A notch in the middle of the hex nut typically indicates a left-hand thread.
 - c. Gaskets are used on some inlet connections. Be sure the gasket is in good shape. Do not over-tighten to avoid squashing the gasket into the gas line. Keep extra gaskets on hand.
 - d. Never use oil or grease on regulator or cylinder fittings, as it may contaminate pure gases, or create a fire hazard.

Pressurizing the system for the first time:

Before system startup, it is recommended that all systems be pressure tested, leak tested, and purged with an inert gas such as nitrogen. To accomplish this with connections other than a CGA 580, it will be necessary to use an adapter.

The recommended use of an adapter is for temporary use only, for system start up and checks. Adapters should never be used on a permanent basis.

1. Wear safety glasses and gloves.
2. Be sure that both ends of all hoses or pigtailed are secured before pressurizing.
3. When first pressurizing, do not stand in front of or contact the Protocol Station or regulator. Slowly open the cylinder valve. Observe the high pressure gauge on the regulator (if available) for a rise in pressure up to full cylinder pressure.
4. Keep the hand wheel or wrench on the open cylinder valve at all times, to allow prompt emergency shut-off.
5. Inspect all connections for leaks and fix any leaks. A leak detection solution may be applied to the connections (if compatible with the application) which indicates leaks by bubbling. To further check for leaks, or if the leak detection solution can not be used, close the cylinder valve for a period of time (recommended 24 hours), and observe the high pressure gauge for a drop in pressure. If so indicated, recheck the CGA connection and all other high-pressure port connections.

SWITCHOVER OPERATION

1. The system is intended to draw from one gas cylinder at a time, with a second cylinder in reserve. Choosing either the right or left cylinder as the primary, slowly open the cylinder valve, leaving the other cylinder valve closed.
2. Open the diaphragm valve on the Protocol Switchover, leaving the reserve valve closed.
3. When the primary cylinder is nearly depleted as indicated on the regulator pressure gauge, close the primary diaphragm valve and cylinder valve. Open the reserve cylinder valve and diaphragm valve to supply the system.
4. After making sure that the diaphragm valve and cylinder valve for the depleted cylinder are closed (fully clockwise), loosen the CGA connection on the depleted cylinder.
5. Replace the depleted cylinder with a full cylinder, leaving the cylinder valve closed. This cylinder is now the reserve cylinder. Leave the cylinder valve on the reserve cylinder closed until it is needed.
6. Repeat steps 1 – 5 when the new primary cylinder is nearly depleted. It is advisable to mark the primary and reserve cylinders.

DISCONNECTING A DEPLETED CYLINDER

1. Before disconnecting a cylinder from the Protocol Station, assure that the cylinder valve is closed (turned fully clockwise).
2. Check the high pressure gauge on the pressure regulator to assure that the pressure in the pigtail is below 500 psig.
3. Loosen the CGA connection a few turns and allow any trapped gas to vent to atmosphere. The pigtail has a check valve in the CGA connection to prevent back flow of gas from the system and prevent the entry of air when the pigtail is disconnected, therefore the pigtail will be pressurized when disconnected. A small amount of gas may escape from the CGA connection for a short period, due to trapped gas pressure.
4. If gas continues to escape after a few seconds, retighten the CGA connection and check all valves to be sure they are closed.
5. Continue loosening the CGA connection and remove the cylinder.
6. If it is ever necessary to disconnect a full cylinder, close the cylinder valve and bleed pressure through the regulator before removing the CGA connection.

MAINTENANCE

On regular intervals, the system should be checked for leaks and proper function. Any leaks in the system should be corrected immediately. The pigtail check valve should also be checked for leaks when a depleted cylinder is removed. Note: the system inlet and pigtail should be pressurized when checking for leaks.

THIS PAGE INTENTIONALLY LEFT BLANK

Warranty Information

This equipment is sold by CONTROLS CORPORATION OF AMERICA under the warranties set forth in the following paragraphs. Such warranties are extended only with respect to the purchase of this equipment directly from CONTROLS CORPORATION OF AMERICA or its Authorized Distributors as new merchandise and are extended to the first Buyer thereof other than for the purpose of resale.

For a period of one (1) year from the date of original delivery (90 days in corrosive service) to Buyer or to Buyer's order, this equipment is warranted to be free from functional defects in materials and workmanship and to conform to the description of this equipment contained in this manual and any accompanying labels and/or inserts, provided that the same is properly operated under conditions of normal use and that regular periodic maintenance and service is performed or replacements made in accordance with the instructions provided. The foregoing warranties shall not apply if the equipment has been repaired: other than by CONTROLS CORPORATION OF AMERICA or a designated service facility or in accordance with written instructions provided by CONTROLS CORPORATION OF AMERICA, or altered by anyone other than CONTROLS CORPORATION OF AMERICA, or if the equipment has been subject to abuse, misuse, negligence or accident.

CONTROLS CORPORATION OF AMERICA's sole and exclusive obligation and Buyer's sole and exclusive remedy under the above warranties is limited to repairing or replacing, free of charge, at CONTROLS CORPORATION OF AMERICA's option, the equipment or part, which is reported to its Authorized Distributor from whom purchased, and which if so advised, is returned with a statement of the observed deficiency, and proof of purchase of equipment or part not later than seven (7) days after the expiration date of the applicable warranty, to the nearest designated service facility during normal business hours, transportation charges prepaid, and which upon examination, is found not to comply with the above warranties. Return trip transportation charges for the equipment or part shall be paid by Buyer.

CONTROLS CORPORATION OF AMERICA SHALL NOT BE OTHERWISE LIABLE FOR ANY DAMAGES INCLUDING BUT NOT LIMITED TO: INCIDENTAL DAMAGES, CONSEQUENTIAL DAMAGES, OR SPECIAL DAMAGES, WHETHER SUCH DAMAGES RESULT FROM NEGLIGENCE, BREACH OF WARRANTY OR OTHERWISE.

THERE ARE NO EXPRESS OR IMPLIED WARRANTIES WHICH EXTEND BEYOND THE WARRANTIES HEREINABOVE SET FORTH. CONTROLS CORPORATION OF AMERICA MAKES NO WARRANTY OF MERCHANTABILITY OR FITNESS FOR A PARTICULAR PURPOSE WITH RESPECT TO THE EQUIPMENT OR PARTS THEREOF.

ADI 3215-B



Controls Corporation of America
1501 Harpers Road Virginia Beach, VA 23454
To Order Call 1-800-225-0473 or 757-422-8330 • Fax 757-422-3125
www.concoa.com