



**580 6001**

# Micron Filter Assembly

**INSTALLATION AND OPERATION INSTRUCTIONS  
NOT FOR OXYGEN OR OTHER OXIDIZING GASES**

Before Installing or Operating, Read and Comply with These Instructions

Controls Corporation of America  
1501 Harpers Road • Virginia Beach, VA 23454  
To Order Call 1-800-225-0473 or 757-422-8330 • Fax 757-422-3125  
[www.concoa.com](http://www.concoa.com)

November 2023

## **USER RESPONSIBILITY**

This equipment will perform in conformity with the description contained in this manual and accompanying labels and/or inserts when installed, operated, maintained, and repaired in accordance with the instructions provided. This equipment must be checked periodically. Improperly working equipment should not be used. Parts that are broken, missing, worn, distorted or contaminated, should be replaced immediately. CONCOA recommends that a telephone or written request for service advice be made to the CONCOA Warranty Administrator in Virginia Beach, Virginia.

This equipment or any of its parts should not be altered without the prior written approval of CONCOA. The user of this equipment shall have the sole responsibility for any malfunction that results from improper use, faulty maintenance, damage, improper repair, or alteration by anyone other than CONCOA or a service facility designated by CONCOA.

## **DESCRIPTION**

This filter assembly is designed to remove system contaminants as small as 2 micron in inert gas service. The filter element can be replaced without removing the filter body from the system.

Replacement 2 micron filter part number: 830 0318

## **CUSTOMER ASSISTANCE**

In the event of equipment failure, call the CONCOA Customer Assistance Line: 1-800-225-0473. Please be prepared to provide the model number and serial number of the equipment involved, in addition to some details regarding its application. This would include inlet and outlet pressures, flow rate, environmental conditions, and gas service. Things to consider before removing the system from the box:

1. Know the properties and special handling requirements of the gas being used. Many specialty gases are dangerous (flammable, toxic, corrosive, simple asphyxiant, or oxidizers). Equipment failure or misuse may lead to problems such as a release of gas. Proper safety measures should be established to handle these and other component failures.
2. Be sure that the assembly purchased is suitable for the gas and type of service intended. The regulator label provides the following information:
  - a) Model Number
  - b) Serial Number
  - c) Maximum inlet pressure
3. Be sure that the equipment received conforms to the order specifications. The user is responsible for selecting equipment compatible with the gas in use, and conditions of pressure, temperature, flow, etc. Selection information can be found in CONCOA technical data sheets. In addition, CONCOA representatives are trained to aid in the selection process.
4. Inspect the assembly upon receipt to be sure that there is no damage or contamination. Pay particular attention to connecting threads. While CONCOA assembles system components to exacting leak-tight standards, the customer should also inspect for any loosening of parts that may occur in shipping or installation. Loose parts may be dangerously propelled from an assembly. If there are adverse signs (leakage or other malfunction), return the assembly to the supplier. While it is advised that soiled products be returned for cleaning, simple external dust or grease may be removed by a clean cloth and, if required, with aqueous detergent suitable for the application. If there are signs of internal contamination, return to the supplier.
5. Before system startup, it is recommended that all systems be pressure tested, leak tested, and purged with an inert gas such as nitrogen. To accomplish this with connections other than a CGA 580, it will be necessary to use an adapter. The recommended use of an adapter is for temporary use for start-up and system checks only. Adapters should never be used on a permanent basis.

## **GENERAL SAFETY PRACTICES**

Comply with precautions listed in C.G.A. Pamphlet P-1, Safe Handling of Compressed Gases in Containers.

Consult the cylinder distributor for the proper use of cylinders and for any restrictions on their use such as flow rate and temperature requirements.

Store cylinders with valve caps screwed on and cylinders chained to a supporting wall or column.

Handle cylinders carefully, and only with valve caps screwed on. The cap will reduce the chance that the cylinder valve will break off if the cylinder is accidentally dropped or falls over. The cap also protects the cylinder valve from damage to screw threads, which could cause leaky connections.

All manifolds used with flammable gases should be provided with approved flashback arrestors to stop any burning gas in the pipeline from getting back to the manifold or cylinders.

No smoking should be permitted near oxygen, nitrous oxide, any other oxidizers, flammable gases, or flammable mixtures, or in areas where cylinders are stored.

Where oxygen or nitrous oxide is used, the manifold and cylinders must be kept clean. No oil, grease, or combustible substances should come in contact with oxygen or nitrous oxide storage or handling equipment. Such materials in contact with oxygen or nitrous oxide are readily ignitable and, when ignited, will burn intensely.

Never use an open flame when leak testing.

Always open valves slowly when high-pressure gases are being used.

Always be sure that a cylinder contains the correct gas before connecting it to any manifold.

Always leak-test any manifold or distribution pipeline before using.

Always be sure that the gas in a pipeline is the correct gas for the intended use.

Always close all cylinder valves before disconnecting cylinders from a manifold.

Always remove all empty cylinders from a manifold before connecting full cylinders.

Always test cylinders to be sure the cylinders are full before connecting to a manifold.

Not for use with Oxygen, oxidizing gas, corrosive or toxic gases.

Maximum inlet pressure = 200 PSIG.

All gas distribution piping systems must meet the appropriate industrial standards for the intended service and must be thoroughly cleaned before using. For the United States, some applicable safety rules and precautions are listed below:

1. American National Standards Institute standard Z49.1, Safety in Welding and Cutting, American Welding Society, 2501 NW Seventh Street, Miami, Florida 33125
2. N.F.P.A. Standard 51, Oxygen-Fuel Gas systems for Welding and Cutting, N.F.P.A., 470 Atlantic Avenue, Boston, Massachusetts 02210
3. N.F.P.A. Standard 51B, Cutting and Welding Processes (same address as #2).
4. CONCOA publication ADE 872, Safety Precautions in Welding and Cutting.
5. Local Ordinances
6. O.S.H.A. Standard 29 CFR
7. C.G.A. Pamphlet C-4, American National Standard Method of Marking Portable Compressed Gas Containers to Identify the Material Contained.
8. C.G.A. Pamphlet G-4, Oxygen – Information on the properties, manufacture, transportation, storage, handling, and use of oxygen.
9. C.G.A. Pamphlet G-4.1, Equipment Cleaned for oxygen service.
10. C.G.A. Pamphlet G-4.4, Industrial Practices for Gaseous Oxygen Transmission and Distribution Piping Systems.
11. C.G.A. Pamphlet G-5, Hydrogen – Information on the properties, manufacture, transportation, storage, handling, and use of hydrogen.
12. C.G.A. Pamphlet G-6, Carbon Dioxide – Information on the properties, manufacture, transportation, storage, handling, and use of carbon dioxide.
13. C.G.A. Pamphlet G-6.1, Standard for Low Pressure Carbon Dioxide Systems at Consumer Sites.
14. C.G.A. Pamphlet P-1, Safe Handling of Compressed Gases in Containers.
15. C.G.A. Safety Bulletin SB-2, Oxygen Deficient Atmospheres.

\*C.G.A. pamphlets can be obtained from:

The Compressed Gas Association, 1235 Jefferson Davis Highway, Arlington, VA 22202-3239  
(703) 979-0900, Publications: (703) 979-4341, Fax: (703) 979-0134.

## **LOCATION**

Keep all cylinders and manifolds away from any source of high temperature over 120°F (50°C) or possible fire hazards. High-pressure gas contained in a closed cylinder becomes increasingly dangerous when exposed to high temperature because pressure increases and the strength of the cylinder decreases. Manifolds installed in open locations should be protected from weather conditions. During winter, protect the manifold from ice and snow. In summer, shade the manifold and cylinders from continuous exposure to direct sunlight. Always leave access to the manifold for cylinder replacement.

## GENERAL INSTALLATION AND OPERATION

### INSTALLING INLET AND OUTLET CONNECTIONS:

The filter assembly connects upstream using a 1/4" compression fitting. The flow arrow located on the filter body indicates the correct direction of the flow of gas. Assemble compression fittings in accordance with the "Compression Tube Fitting Connections Procedure" below.

#### Compression Tube Fitting Connections Procedure:

Use a tubing cutter to cut tubes to length. Do not deform the tube by, for example, clamping it too tightly in a vise. De-burr cut ends of the tubing. Tubing must be clean, free of oils, grease, metal chips, and contaminants. Assure that tube fitting components are properly assembled. Insert the tube into the compression tube fitting until tube is resting against the internal shoulder of the fitting. The tube must bottom out against the internal shoulder. If it does not, the tube may pull out in operation. Tighten the loose nut finger tight, and mark it and the fixed nut at the 6 o'clock position.

Tighten the loose nut as follows:

- For  $\varnothing 1/4$ " ( $\varnothing 6$ mm) tube fittings and larger: tighten 1-1/4 turns.
- For tube fittings smaller than  $\varnothing 1/4$ " ( $\varnothing 6$ mm): tighten 3/4 turn.

NOTE: Tube fitting suppliers can provide feeler gauges to measure the gap between the loose nut and the fixed nut for 100% certainty of proper tightness at 1st assembly (feeler gauge is not to be used after 1st assembly).

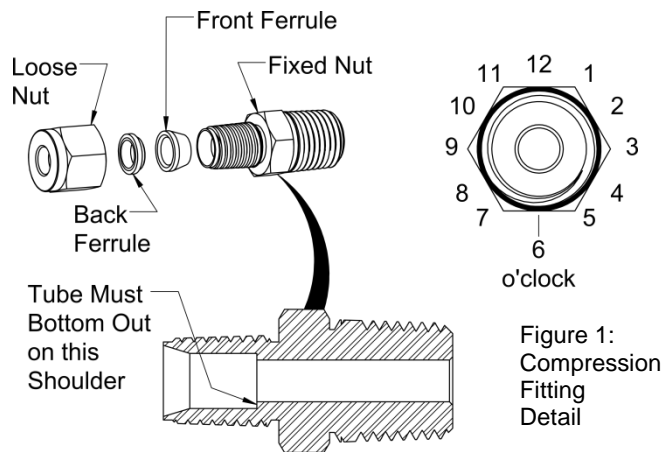

## Follow these rules when using PTFE tape:

- Do not use oil or grease on fittings. This is especially important for oxidizing gas service.
- PTFE tape must be used on NPT threads to ensure a gas-tight seal. Avoid impinging on the gas stream. PTFE tape also helps to prevent the connections from galling together when tightening or loosening.
- Before applying PTFE tape, inspect the NPT threads, and, if necessary, clean the fitting to remove any dirt or thread sealant that remains on the threads.
- Start the PTFE tape on the first thread, leaving a slight section of the chamfer exposed as shown in Figure 4. Make sure the tape does not overlap the end of the fitting.
- As tape is wound in the direction of the thread spiral, pull tightly on the end of the tape so that the tape conforms to the thread.
- Apply at least 2 but no more than 3 layers of tape to the threads. Press the end firmly into the threads.

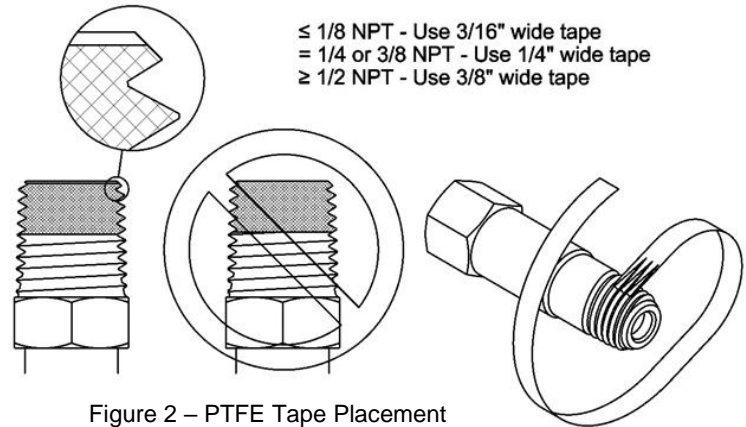

Figure 2 – PTFE Tape Placement

## OPERATION

Install, purge, and open both valves on filter assembly. If undesirable flow or pressure drop occurs, change filter element as described in the MAINTENANCE section of this instructions manual below.

## MAINTENANCE

On regular intervals, the system should be checked for leaks and proper function. Any leaks in the system should be corrected immediately.

### Filter Replacement Instructions

#### Disassembly

- Close inlet valve on Assembly.
- Close outlet valve after inlet valve is completely closed.
- Slowly loosen bonnet nut to vent any pressure that may be present. After all venting has stopped, remove bonnet assembly (bonnet nut, bonnet, spring and retaining ring) from body.
- If replacing filter element, remove used element and discard.

#### Reassembly

- Before reassembling the filter, be certain all components are clean and free of contamination.
- Align the new element parallel to the filter bore, positioning the open end of the element towards the body, and press securely in place.
- Lubricate gasket with thin film of system compatible lubricant. Place gasket on body sealing surface.
- If installing a new spring, press the spring into the bonnet with the large end of the spring first (see filter cross-section detail).

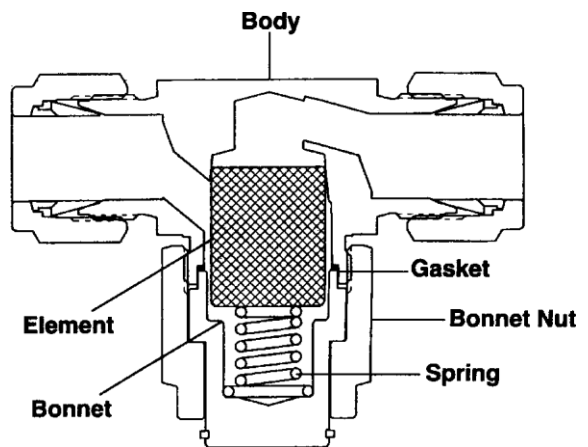

Figure 3 – Filter Cross-Section

5. Holding the body stationary, thread the bonnet assembly onto the body finger-tight.
6. Tighten the bonnet nut to 500 in-lbs (75 N-m) torque.
7. Test the filter for proper operation and leak tight sealing.

## **SERVICE**

A unit that is not functioning properly should not be used. It is recommended that all servicing be done by a service facility authorized by CONCOA. Contact CONCOA Customer Service in Virginia Beach, Virginia for systems still covered by the warranty. For items not covered by the warranty, contact the nearest CONCOA District Sales Office for assistance. Contact CONCOA by phone toll-free 1-800-225-0473, FAX: 1-757-422- 3125, or by email, e-mail@concoa.com.

If so advised, the unit should be sent to a service facility authorized by CONCOA. Do the following before shipping:

1. Adequately package the system. If possible package in the original shipping container.
2. Ship prepaid.
3. Include a statement of the observed deficiency.
4. Indicate the gas service that the equipment was used on.
5. Purge all equipment before shipment to protect the transporter and service personnel.  
The purging is especially important if the equipment has been in hazardous or corrosive gas service.

## Warranty Information

This equipment is sold by CONTROLS CORPORATION OF AMERICA under the warranties set forth in the following paragraphs. Such warranties are extended only with respect to the purchase of this equipment directly from CONTROLS CORPORATION OF AMERICA or its Authorized Distributors as new merchandise and are extended to the first Buyer thereof other than for the purpose of resale.

For a period of one (1) year from the date of original delivery (90 days in corrosive service) to Buyer or to Buyer's order, this equipment is warranted to be free from functional defects in materials and workmanship and to conform to the description of this equipment contained in this manual and any accompanying labels and/or inserts, provided that the same is properly operated under conditions of normal use and that regular periodic maintenance and service is performed or replacements made in accordance with the instructions provided. The foregoing warranties shall not apply if the equipment has been repaired: other than by CONTROLS CORPORATION OF AMERICA or a designated service facility or in accordance with written instructions provided by CONTROLS CORPORATION OF AMERICA, or altered by anyone other than CONTROLS CORPORATION OF AMERICA, or if the equipment has been subject to abuse, misuse, negligence or accident.

CONTROLS CORPORATION OF AMERICA's sole and exclusive obligation and Buyer's sole and exclusive remedy under the above warranties is limited to repairing or replacing, free of charge, at CONTROLS CORPORATION OF AMERICA's option, the equipment or part, which is reported to its Authorized Distributor from whom purchased, and which if so advised, is returned with a statement of the observed deficiency, and proof of purchase of equipment or part not later than seven (7) days after the expiration date of the applicable warranty, to the nearest designated service facility during normal business hours, transportation charges prepaid, and which upon examination, is found not to comply with the above warranties. Return trip transportation charges for the equipment or part shall be paid by Buyer.

**CONTROLS CORPORATION OF AMERICA SHALL NOT BE OTHERWISE LIABLE FOR ANY DAMAGES INCLUDING BUT NOT LIMITED TO: INCIDENTAL DAMAGES, CONSEQUENTIAL DAMAGES, OR SPECIAL DAMAGES, WHETHER SUCH DAMAGES RESULT FROM NEGLIGENCE, BREACH OF WARRANTY OR OTHERWISE.**

**THERE ARE NO EXPRESS OR IMPLIED WARRANTIES WHICH EXTEND BEYOND THE WARRANTIES HEREINABOVE SET FORTH. CONTROLS CORPORATION OF AMERICA MAKES NO WARRANTY OF MERCHANTABILITY OR FITNESS FOR A PARTICULAR PURPOSE WITH RESPECT TO THE EQUIPMENT OR PARTS THEREOF.**