

HARD HAT REGULATOR GUARD FOR REGULATOR 8400 and 9400

To Protect Regulator from Damage By Impact

INSTALLATION

ADI 1678-E

CAUTION

Remove regulator from cylinder before installing.

1. Remove adjusting screw (counterclockwise).
2. Spread sides of guard and, holding as shown left, place back cap in opening.

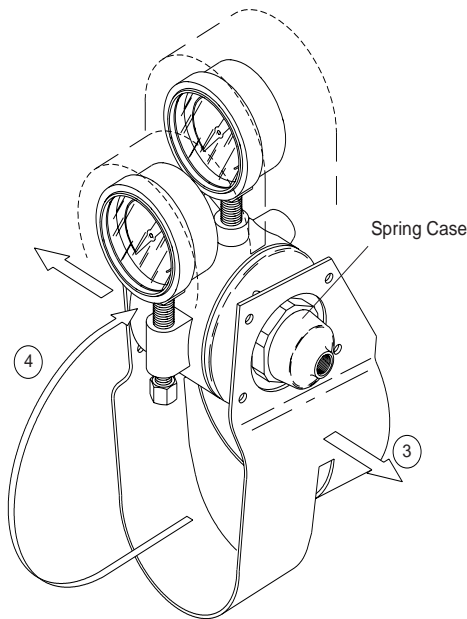
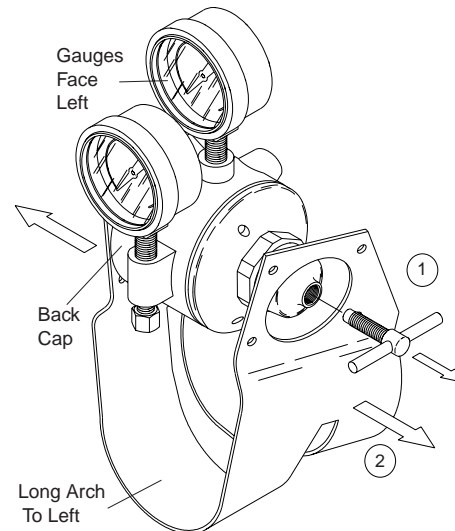

3. Spread sides until spring case is inside other opening.
4. Rotate guard (clockwise only) to position show by broken lines in figure to the left.

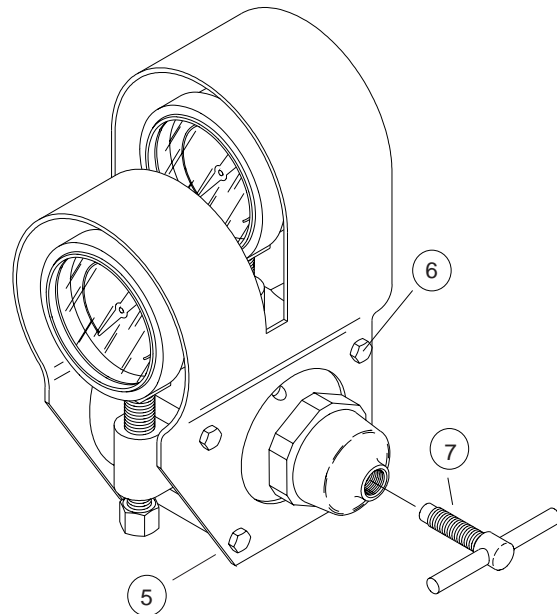

5. Squeeze sides together and install two (2) lower bolts and nuts to hold guard in place (nuts in rear). Four (4) both/nut sets are provided.
6. Install position bolt between body bosses close to body as shown, align gauges parallel to guard with regulator centered in openings, and tighten all bolts.
7. Replace adjusting screw and connect regulator to cylinder as usual.

For Maximum Safety Use Flashback Arrestors

Regulator Mounted Model 78 Resettable	Regulator Mounted Model 53
--	-------------------------------

801-0786 'B' Size (Oxy)
801-0789 'B' Size (Fuel)
UL Listed

801-0536 'B' Size (Oxy)
801-0539 'B' Size (Fuel)
Meets OSHA Requirements

Comply with ISO 5175

Controls Corporation of America
1501 Harpers Road • Virginia Beach, VA 23454
Phone 757-422-8330 • Fax 757-422-3125
Phone Orders 1-800-225-0473
<http://www.concoa.com>



USER RESPONSIBILITY

This equipment will perform in conformity with the description thereof contained in this manual and accompanying labels and/or inserts when installed, operated, maintained and repaired in accordance with the instructions provided. This equipment must be checked periodically. Defective equipment should not be used. Parts that are broken, missing, plainly worn, distorted or contaminated, should be replaced immediately. Should such repair or replacement become necessary, Controls Corporation of America (CONCOA) recommends that a telephonic or written request for service advice be made to CONCOA Customer Service in Virginia Beach, Virginia, PHONE: 1-757-422-8330 or Toll Free in the US and Canada 1-800-225-0473, FAX: 1-757-422-3125, or E-MAIL: e-mail@concoa.com.

This equipment or any of its parts should not be altered without the prior written approval of CONCOA. The user of this equipment shall have the sole responsibility for any malfunction which results from improper use, faulty maintenance, damage, improper repair or alteration by anyone other than CONCOA or a service facility designated by CONCOA.

WARRANTY INFORMATION

This equipment is sold by CONTROLS CORPORATION OF AMERICA under the warranties set forth in the following paragraphs. Such warranties are extended only with respect to the purchase of this equipment directly from CONTROLS CORPORATION OF AMERICA or its Authorized Distributors as new merchandise and are extended to the first Buyer thereof other than for the purpose of resale.

For a period of one (1) year from the date of original delivery (90 days in corrosive service) to Buyer or to Buyer's order, this equipment is warranted to be free from functional defects in materials and workmanship and to conform to the description of this equipment contained in this manual and any accompanying labels and/or inserts, provided that the same is properly operated under conditions of normal use and that regular periodic maintenance and service is performed or replacements made in accordance with the instructions provided. The foregoing warranties shall not apply if the equipment has been repaired: other than by CONTROLS CORPORATION OF AMERICA or a designated service facility or in accordance with written instructions provided by CONTROLS CORPORATION OF AMERICA, or altered by anyone other than CONTROLS CORPORATION OF AMERICA, or if the equipment has been subject to abuse, misuse, negligence or accident.

CONTROLS CORPORATION OF AMERICA's sole and exclusive obligation and Buyer's sole and exclusive remedy under the above warranties is limited to repairing or replacing, free of charge, at CONTROLS CORPORATION OF AMERICA's option, the equipment or part, which is reported to its Authorized Distributor from whom purchased, and which if so advised, is returned with a statement of the observed deficiency, and proof of purchase of equipment or part not later than seven (7) days after the expiration date of the applicable warranty, to the nearest designated service facility during normal business hours, transportation charges prepaid, and which upon examination, is found not to comply with the above warranties. Return trip transportation charges for the equipment or part shall be paid by Buyer.

CONTROLS CORPORATION OF AMERICA SHALL NOT BE OTHERWISE LIABLE FOR ANY DAMAGES INCLUDING BUT NOT LIMITED TO: INCIDENTAL DAMAGES, CONSEQUENTIAL DAMAGES, OR SPECIAL DAMAGES, WHETHER SUCH DAMAGES RESULT FROM NEGLIGENCE, BREACH OF WARRANTY OR OTHERWISE.

THERE ARE NO EXPRESS OR IMPLIED WARRANTIES WHICH EXTEND BEYOND THE WARRANTIES HEREIN-ABOVE SET FORTH. CONTROLS CORPORATION OF AMERICA MAKES NO WARRANTY OF MERCHANTABILITY OR FITNESS FOR A PARTICULAR PURPOSE WITH RESPECT TO THE EQUIPMENT OR PARTS THEREOF.

Controls Corporation of America
1501 Harpers Road • Virginia Beach, VA 23454
Phone 757-422-8330 • Fax 757-422-3125