



**522 Series
AutoSwitch
Systems
(Brass)**

**523 Series
AutoSwitch
Systems
(Stainless Steel)**

**For use with Non-Toxic and Non-Corrosive Gases
in High Purity Applications**

INSTALLATION AND OPERATION INSTRUCTIONS

Before Installing or Operating, Read and Comply with These Instructions

Controls Corporation of America
1501 Harpers Road Virginia Beach, VA 23454
Telephone 1-800-225-0473 or 757-422-8330 • Fax 757-422-3125
www.concoa.com

DESCRIPTION OF PRODUCT

The brass 522 Series and the stainless steel 523 Series AutoSwitches are automatic switchover systems designed to provide a continuous supply of high purity gas. This unit may be used with one cylinder per side or with manifolds for increased storage capacity. The inlets of the switchover system may be configured with open ports, diaphragm valves, manifold connectors, or flexible hoses. The system, when configured with manifold connectors, is for use with the 52B (brass) or 52S (stainless steel) Series manifold systems. The standard AutoSwitch system will maintain a regulated line pressure within the values shown in the table below:

MODEL	RANGE
522 or 523 2XXX	0-50 PSI (0-3.5 BAR)
522 or 523 3XXX	0-100 PSI (0-7 BAR)
522 or 523 4XXX	0-200 Psi (0-14 BAR)
522 or 523 5XXX	0-350 PSI (0-24 BAR)
522 or 523 7XXX	0-150 PSI (0-10 BAR)

The inlet pressure must be maintained above the value listed in the table below for the system to operate properly.

MODEL	RANGE
522 or 523 2XXX	265 PSI (18 BAR)
522 or 523 3XXX	265 PSI (18 BAR)
522 or 523 4XXX	345 PSI (24 BAR)
522 or 523 5XXX	540 PSI (37 BAR)
522 or 523 7XXX	265 PSI (18 BAR)

Models of these AutoSwitches are available with neither pressure switches nor transducers (these are not compatible with remote alarms), with inlet pressure switches, or with inlet pressure transducers. None of these AutoSwitches can be connected directly to AC line voltage. Models with inlet pressure switches or transducers can be configured for use with CONCOA's optional Altos 2 Remote Alarm *.

Models with pressure switches include a front Power Indicator light and LED status lights to indicate the condition of the gas cylinders. A green indicator light signifies a "Normal" condition while a red light indicates an "Alarm" (Gas cylinder empty) condition. The pressure switch AutoSwitch systems also include a strain relief on the bottom through which wiring can be connected to an internal circuit board and to a remote alarm such as CONCOA's Altos 2 *.

For models with pressure transducers, the status of the gas cylinder pressures can be viewed on the optional Altos 2 Remote Alarm *.

* Refer to instruction manual 9906 0025-24V (ADI0025-24V) for the CONCOA Altos 2 Remote Alarm wiring and operating instructions.

Figure 1

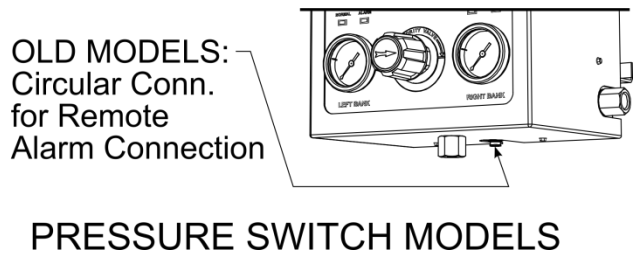
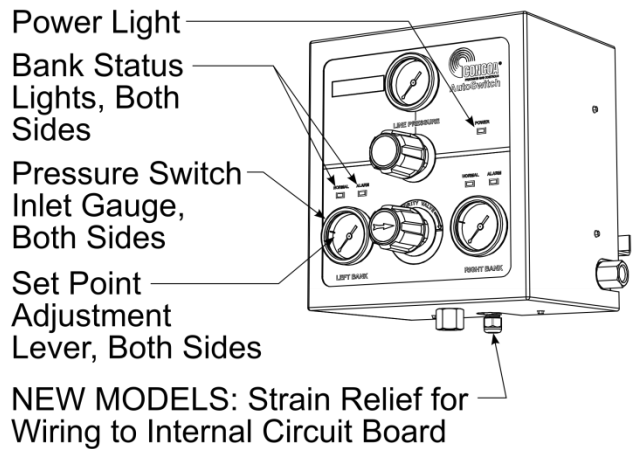
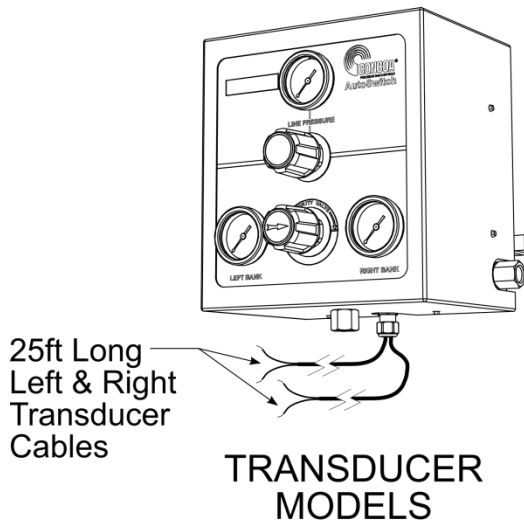
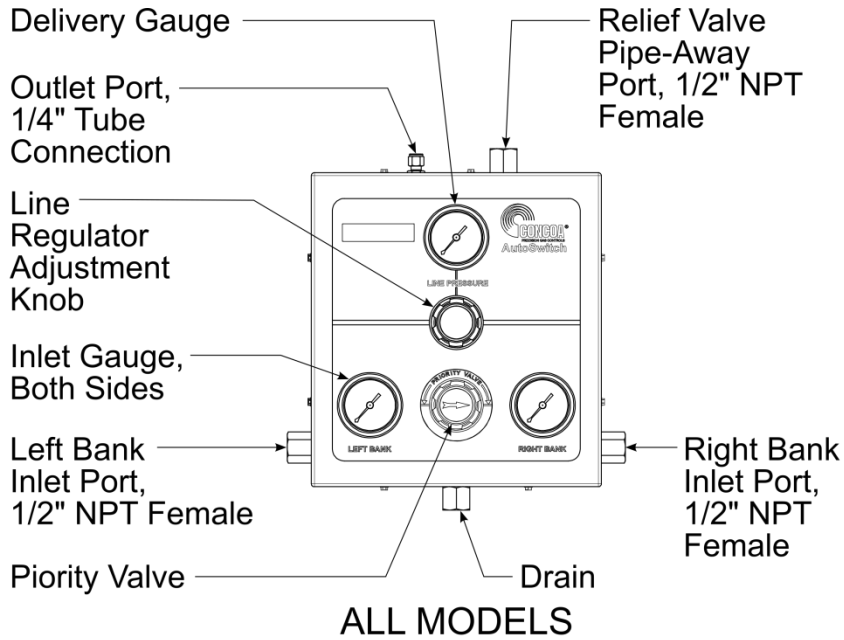

INTENDED USE OF PRODUCT

The brass 522 series and the stainless steel 523 Series AutoSwitch systems are intended for use in high purity, non-corrosive, non-toxic applications. Please note the safety information shown in the later sections.

USER RESPONSIBILITY

The User of this equipment should follow all labeling, installation, and operation instructions when using this equipment. It is recommended that the user review all safety precautions listed in the safety section of this manual.

Know the properties and special handling requirements of the gas being used. Many gases are dangerous (flammable, toxic, corrosive, etc.) Consult with the cylinder distributor for the proper use of the cylinders and any restrictions in their use. This equipment must be checked periodically. Improperly working equipment should not be used. Broken, worn, distorted, contaminated, or missing components should be replaced by a trained technician immediately.

CUSTOMER ASSISTANCE

In the event of equipment failure, call the CONCOA Customer Assistance Line: 1-800-225-0473. Please be prepared to provide the model number and serial number of the equipment involved in addition to some details regarding its application. This would include inlet and outlet pressures, flow rate, environmental conditions, and gas service.

SAFETY

Carefully read and comply with these instructions before installing or operating any high pressure gas manifold. These manifolds are designed, manufactured, and tested to conform to industry standards for safety for high pressure gas manifolds for a maximum inlet pressure of 3500 PSI (241 bar).

Always observe the following safety practices:

- √ Store cylinders with valve caps screwed on and cylinders chained to a supporting wall or column.
- √ Handle cylinders carefully and only with valve caps screwed on. The cap will prevent the cylinder valve from breaking off at the top of the cylinder if the cylinder is accidentally dropped or falls over. The cap also protects the cylinder valve from damage to screw threads, which could cause leaky connections.
- √ Due to the highly combustible nature of hydrogen, methane, ethylene, and fuel gases, all manifolds used with this gas are provided with flashback arrestors to stop any burning gas in the pipeline from getting back to the manifold or cylinders. Flashback arrestors are either water filled or dry check valve type. Gas flowing from the regulators on the manifold flows through the flashback arrestor to the pipeline. Arrestors on hoses are required for acetylene service.
- √ Keep all cylinders away from any source of high temperature (not over 120° F, 50° C) or possible fire hazards. High-pressure gas contained in a closed cylinder becomes increasingly dangerous when exposed to high temperature because pressure increases and the strength of the cylinder decreases.
- √ No smoking should be permitted near oxygen, nitrous oxide, flammable gases, or flammable mixtures or in areas where cylinders are stored.

- √ Where oxygen or nitrous oxide is used, the manifold and cylinders must be kept clean. No oil, grease, or combustible substances should come in contact with oxygen or nitrous oxide storage or handling equipment. Such materials in contact with oxygen or nitrous oxide are readily ignitable and, when ignited, will burn intensely.
- √ Never lift gas cylinders with a magnetic lifting device.
- √ Never use an open flame when leak testing.
- √ Always open valves slowly when high-pressure gases are being used. Open valves all the way.
- √ Always be sure that a cylinder contains the correct gas before connecting it to any manifold.
- √ Always leak-test any manifold or distribution pipeline before using.
- √ Always be sure that the gas in a pipeline is the correct gas for the intended use.
- √ Always install a blind gland and nut or piping plug on any manifold inlet fitting if no cylinder is connected to the fitting before opening any cylinder valve which is already connected to the manifold.
- √ Always close all cylinder valves before disconnecting cylinders from a manifold.
- √ Always remove all empty cylinders from a manifold before connecting full cylinders.
- √ Always test cylinders to be sure they are full before connecting to a manifold.
- √ NOTE: Use of PTFE lined hoses for oxygen installations is not recommended unless they are equipped with a Distance Volume Piece (DVP). Components in the manifold system can create a dead end passage. The combination of a dead end passage coupled with a rapid pressurization may lead to adiabatic compression of the contained oxygen and subsequent failure of the hose by ignition.
- √ All gas distribution piping systems must meet appropriate industrial standards for the intended service, and must be thoroughly cleaned before using.

Comply with all safety rules and precautions of the following:

1. American National Standards Institute standard Z49.1 or Safety in Welding and Cutting, American Welding Society, 2501 NW Seventh Street, Miami, FL 33125.
2. N.F.P.A. Standard 51, Oxygen-Fuel Gas Systems for Welding and Cutting, N.F.P.A., 470 Atlantic Avenue, Boston, MA 02210.
3. N.F.P.A. Standard 51B, Cutting and Welding Processes, (see Address in #2)
4. CONCOA Publication ADE 872, Safety Precautions in Welding and Cutting.
5. Local ordinances.
6. O.S.H.A.
7. C.G.A. Pamphlet C-4, American National Standard Method of Marking Portable Compressed Gas Containers to Identify the Material Contained.
8. C.G.A. Pamphlet G-4, Oxygen-Information on the properties, manufacture, transportation, storage, handling, and use of oxygen.
9. C.G.A. Pamphlet G-4.1, Equipment Cleaned for Oxygen Service.
10. C.G.A. Pamphlet C-4.4, Industrial Practices for Gaseous Oxygen Transmission and Distribution Piping Systems.

11. C.G.A. Pamphlet G-5, Hydrogen - Information on the properties, manufacture, transportation, storage, handling, and use of hydrogen.
12. C.G.A. Pamphlet G-6, Carbon Dioxide - Information on the properties, manufacture, transportation, storage, handling, and use of carbon dioxide.
13. C.G.A. Pamphlet G-6.1, Standard for Low Pressure Carbon Dioxide Systems at Consumer Sites.
14. C.C.A. Pamphlet P-1, safe handling of compressed gases in containers.

CAUTION

INSTALLATION

The site chosen for the installation of the system shall be level, well ventilated, and at a safe distance from sources of flames, sparks, and excessive heat. The system should not be placed in an area that may subject it to damage from passing trucks, cranes, or other heavy machines. Any oxygen system must not be installed under shafting, belting, or other places where oil can drip on it. Refer to the manifold instructions for manifold installation.

- a. Be sure to consider all factors when selecting materials.
- b. Do not use oil or grease on fittings.
- c. Be sure that all fittings are secure and leak tight. PTFE tape must be used on pipe threads. See Figure 6.
- d. Relief valve: The purpose of the relief valve is to protect the AutoSwitch system and its components only (Figure 2). If there is pressure sensitive equipment downstream of the AutoSwitch system, it is recommended that an appropriately sized relief valve be installed in the line to protect this equipment.
- e. CAPTIVE VENTS: These AutoSwitches are available with internal captive vents installed on all internal regulator bonnets. These captive vents are used to capture the most probable internal system leaks, and they are tied into the pipe-away relief valve plumbing so that the leaking gas can be piped away and discharged in a safe area.

CAUTION

WARNING: Equipment failure or misuse may lead to problems such as a release of gas through the relief valve or regulator diaphragm. The AutoSwitch box is not sealed and will leak gas from faulty components. Proper safety measures should be established to handle these and other component failures.

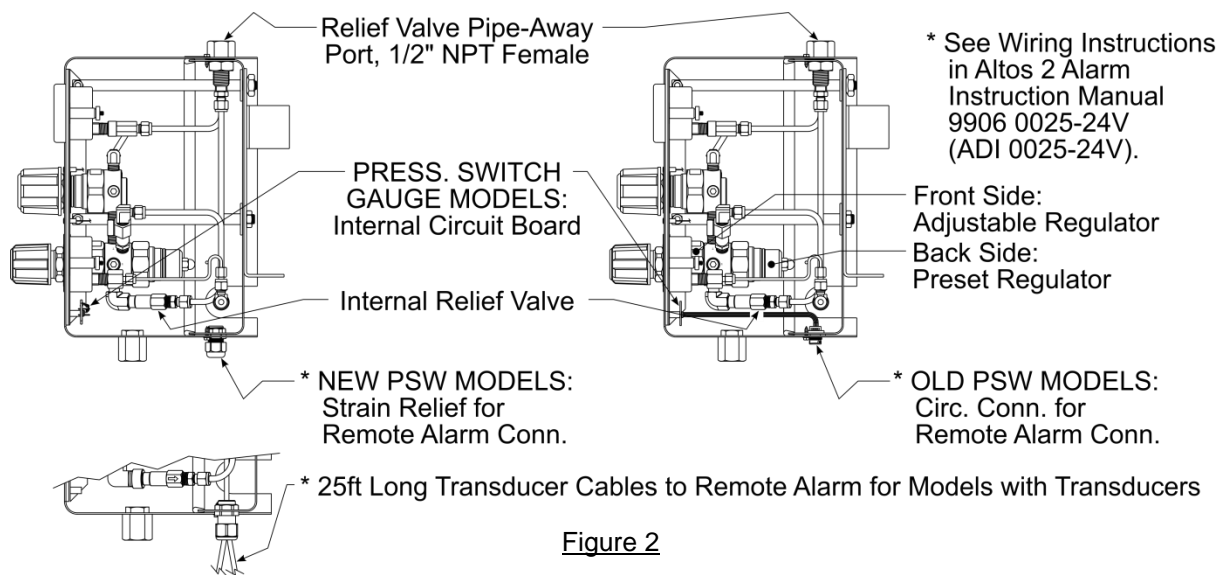

Figure 2

WALL MOUNTING

Follow Compressed Gas Association, OSHA and all applicable local codes. Manifolds should not be placed in locations where the temperature will exceed 102°F (49°C) or fall below 0°F (-18°C). Manifolds installed in open locations should be protected from weather conditions. During winter, protect the manifold from ice and snow. In summer, shade the manifold and cylinders from continuous exposure to direct sunlight. Always leave access to the manifold for cylinder replacement.

1. Determine and mark the vertical center line for installation of the AutoSwitch Console. (Figure 3).
2. Measure from the floor 72" in height at this center line. With the AutoSwitch mounting bracket at this height, the manifold header will be approximately 66" from the floor. Using a level, mark a horizontal line at this point extending approximately 10 inches to the left and right of center.
3. Remove the mounting bracket from the rear of the AutoSwitch Console by removing the retaining nuts at the bottom of the mounting bracket (Figure 5). Place the upper edge of the bracket cross-member on the horizontal line so that it is centered with the vertical line. Holding the bracket with the slotted extensions away from the wall, mark the location of the two mounting bolts (Figure 4)
4. Using appropriate hardware based on wall construction, anchor the mounting bracket to the wall (Figure 4).
5. Place the AutoSwitch system so that the mounting bracket slots align with the shoulder nuts. With the AutoSwitch box hanging on the shoulder nuts, align the retaining bolts so that they protrude through the bracket. Replace the mounting nuts that were removed in step 3.

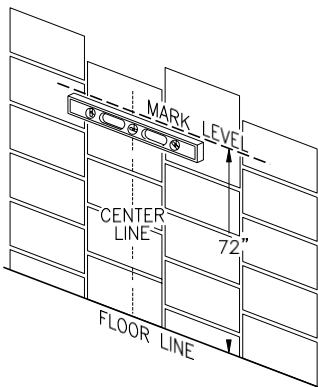

Figure 3 - Center-line Mark

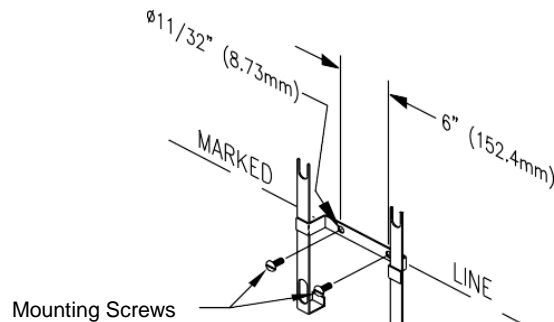

Figure 4 - Mounting Bracket

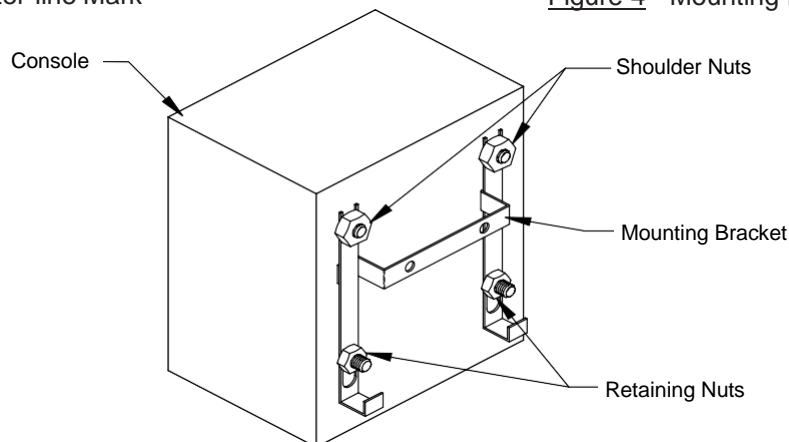

Figure 5 – Console and Mounting Bracket

INLET AND OUTLET CONNECTIONS

General:

Use an open-end wrench, not a pipe wrench, to install accessories to the AutoSwitch system. **ALWAYS hold the bulkhead fitting with a wrench when installing the accessories to the AutoSwitch system. Do not allow the bulkhead fitting to turn; otherwise, connections inside the box may be loosened.** NPT connections require the use of PTFE tape on the threads to make a gas tight seal. (See Figure 6.) CONCOA uses PTFE tape on all of its NPT connections. Follow these rules when using PTFE tape.

- Do not use oil or grease on fittings. This is especially important for oxidizing gas service.
- PTFE tape must be used on NPT threads to ensure a gas tight seal. Avoid impinging on the gas stream. On stainless steel connections, PTFE tape also helps to prevent the connections from galling together when tightening or loosening.
- Before applying PTFE tape, inspect the NPT threads, and, if necessary, clean the fitting to remove any dirt or thread sealant that remains on the threads.
- Start the PTFE tape on the first thread leaving a slight section of the chamfer exposed as shown in Fig. 6. Make sure the tape does not overlap the end of the fitting.
- As tape is wound in the direction of the thread spiral, pull tightly on the end of the tape so that the tape conforms to the thread.
- Apply at least 2 but no more than 3 layers of tape to the threads, and cut off excess tape.
- Press the end firmly into the threads.

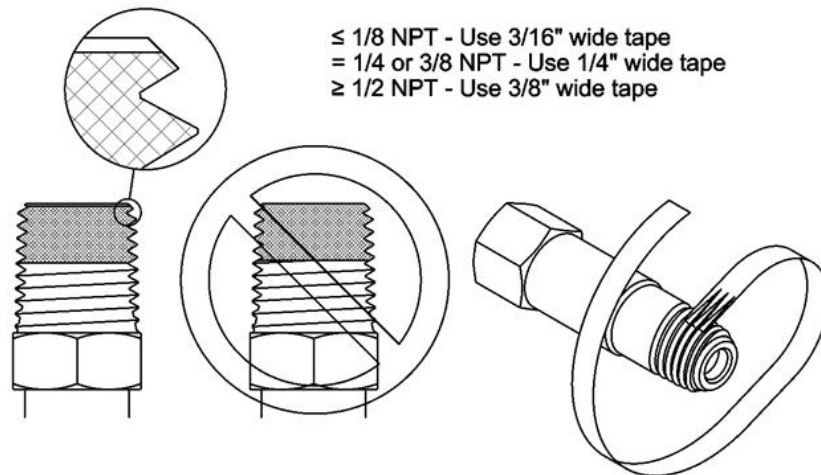

Figure 6 - Pictorial View of Tape Seal

Installing the inlet connection:

When Using a Manifold System:

The 1/2" male NPT end of the manifold connector will need to be installed in the inlet port of the AutoSwitch. The other end of the manifold connector will be connected to the starter block of the 52B (brass) or 52S (stainless steel) Series Manifold system. Please follow the instructions provided with the manifold system when connecting and operating the manifold system.

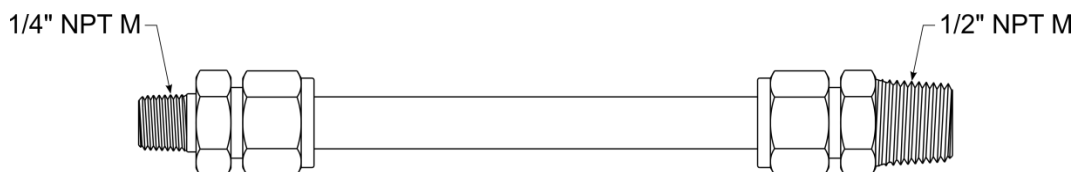
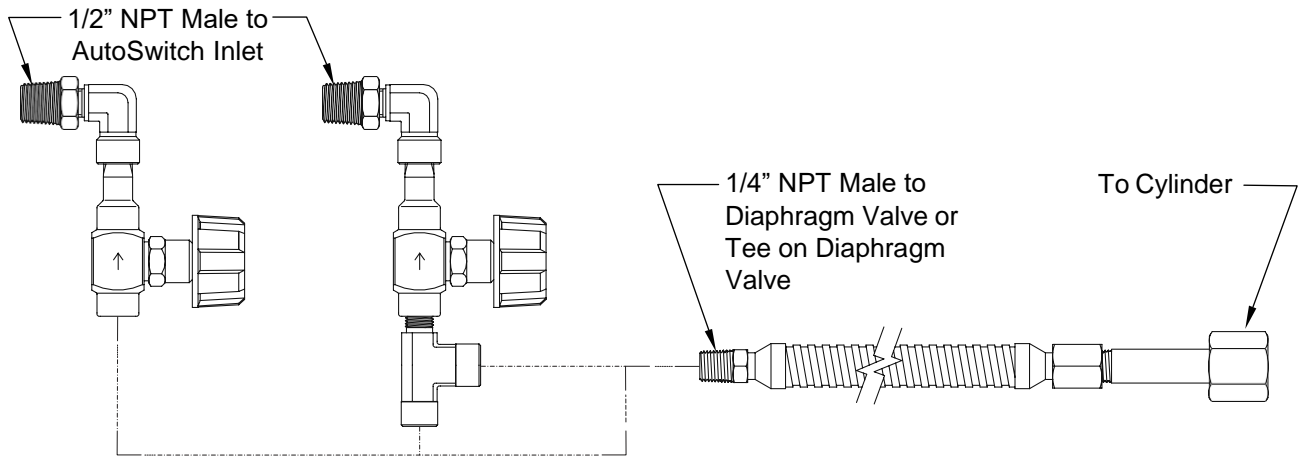

Figure 7 - Manifold Connector for the Maniflex System

For Non-Manifold Use:

If purchased with diaphragm valves, the male 1/2" NPT ends of the diaphragm valve elbows are installed into the inlet ports of the switchover system. Install the male 1/4" NPT end of each pigtail into the open diaphragm valve ports.

The connection available at the other end of the hose will depend on how the system was purchased. If the hose does not have a cylinder connection installed, there will be a female 1/4" NPT thread on the end of the hose. The female 1/4" NPT hose end will connect to the user's system. If configured with a CGA connection or foreign inlet connection, the connection will be specific to the particular cylinder of gas to be used. Some connections do require the use of a gasket. Please note that the material of the gasket must be compatible with the type of gas being used. Be familiar with the type of connection being used and its proper procedures for installation.



Connecting to a cylinder:

1. Before removing the cylinder cap, move the cylinder of gas to the work site:
 - a. Secure cylinder to the floor, wall, or bench with appropriate chain, strap, or stand to prevent toppling.
 - b. Remove the cylinder cap.
 - c. Be sure the cylinder valve is tightly closed (clockwise)
 - d. Remove the cylinder valve plug, if any.
 - e. Inspect the cylinder valve and threads for damage or contamination.
2. Secure the cylinder connection to the cylinder in the following manner:
 - f. Do not force. Tightening the nut onto the cylinder connection should be easy. If it is not, the connection may be wrong for the type of gas being used.
 - g. Left-hand threads are used on some cylinder connections. A notch in the middle of the hex nut typically indicates a left-hand thread.
 - h. Gaskets are used on some inlet connections. Be sure the gasket is in good shape. Do not over-tighten to avoid squashing the gasket into the gas line. Keep extra gaskets on hand.
 - i. Never use oil or grease on regulator or cylinder fittings, as it may contaminate pure gases or create a fire hazard.

Installing the Outlet Connection:

The AutoSwitch system has the outlet connection at the top of the box. The connection is a 1/4" tube connection. Connect tubing to the AutoSwitch that is compatible with the application and is capable of handling the pressure required.

Pressurizing the System for the First Time (Non-Manifold Use):

Before system startup, it is recommended that all systems be pressure tested, leak tested, and purged with an inert gas such as nitrogen. To accomplish this with connections other than a CGA 580, it will be necessary to use an adapter. The recommended use of an adapter is for temporary use only for system start up and checks. Adapters should never be used on a permanent basis.

1. Wear safety glasses and gloves.
2. Be sure that both ends of all hoses are secured before pressurizing. Turn the line regulator knob counterclockwise until the knob stops turning.
3. When first pressurizing, do not stand in front of or contact the switchover system. Slowly open the cylinder valve. Observe the high pressure gauge for a rise in pressure up to full cylinder pressure.
4. Keep the hand wheel or wrench on the open cylinder valve at all times to allow prompt emergency shut-off.
5. Inspect all connections for leaks, and fix any leaks. A leak detection solution may be applied to the connections (if compatible with the application) which indicates leaks by bubbling. To further check for leaks or if the leak detection solution cannot be used, close the cylinder valve for a period of time (recommended 24 hours), and observe the high pressure gauge for a drop in pressure. If so indicated, recheck the CGA connection and all other high-pressure port connections. Never attempt to fix a leak under pressure. If leaks are detected, depressurize the system and retighten the connection. Begin again at step 3.



WARNING: While CONCOA assembles the AutoSwitch system components to exacting leak-tight standards, the customer should also inspect for any loosening of internal parts that may occur in shipping or installation by completing the pressure decay test detailed above. If all external leaks have been found and corrected and the system still indicates a leak, disassemble the front cover from the AutoSwitch after removing the eight screws shown below. Check for leaks on the system's fittings as described above.

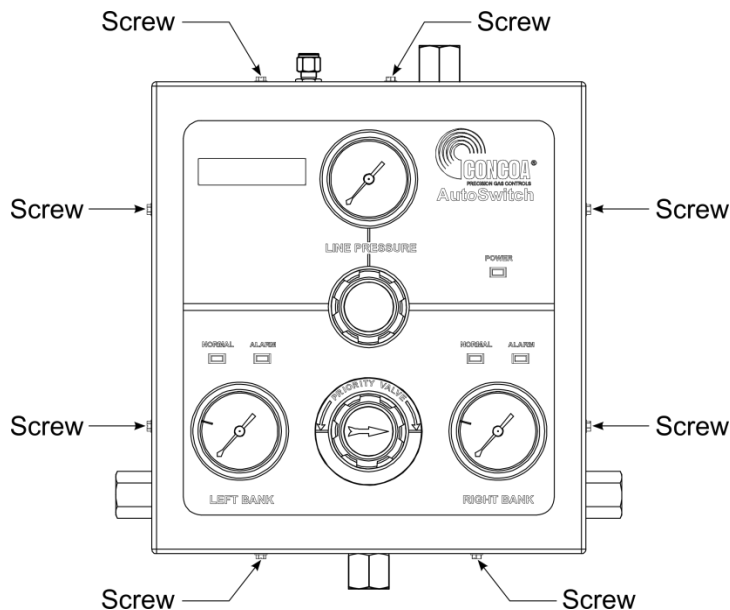

6. Slowly turn the line regulator knob clockwise. This will increase the pressure of the line. Adjust to the desired working pressure, and again check for leaks using the methods described above.

OPERATION

The arrow on the priority valve always points to the primary side. The bank opposite the primary side is considered the reserve side. Starting with the arrow pointing to the right side, gas will flow from the right side cylinder. As the gas in the primary side is depleted, the gas pressure will drop on the right gauge. When the inlet pressure drops to the pressure setting of the reserve side regulator, flow will begin from the reserve cylinder; the inlet pressure on the primary side will stabilize. This is called a changeover. At this point, the gas pressure on the reserve side (preset regulator – see Figure 2) will drop. This indicates that it is time to change the cylinders on the primary side. Before removing the nearly depleted primary cylinder, the priority valve should be rotated 180°. This makes the reserve cylinder the primary source. Remove the depleted cylinder and replace with a full cylinder. Before removing the cylinder, be sure to close the cylinder valve and any other valves that connect the cylinder to the system. The full replacement cylinder is now the reserve cylinder. Note: while changing cylinders on one side, there will be no interruption in flow. A depleted cylinder will have the following gas pressure remaining:

MODEL	RANGE
522 or 523 2XXX	195-265 PSI (13.5-18.5 BAR)
522 or 523 3XXX	195-265 PSI (13.5-18.5 BAR)
522 or 523 4XXX	245-345 PSI (16.5-23.5 BAR)
522 or 523 5XXX	440-540 PSI (30.5-37 BAR)
522 or 523 7XXX	195-265 PSI (13.5-18.5 BAR)

Gas will continue to flow from the primary side until the outlet pressure of the preset regulator matches the pressure of the priority valve regulator (the pressure setting of the priority valve regulator changes when the knob is turned 180°). When the gas pressure stops dropping on the preset regulator and starts to drop on the priority valve regulator, it is time to change the left cylinder. The knob is rotated 180° to the right before the left cylinder is changed. It is helpful to maintain a log of cylinder pressure, noting which direction the arrow is pointing on the priority valve. When the pressure gauge is very low and the reserve side indicates that gas has begun to flow from the reserve cylinder, it is time to rotate the knob and attach a full cylinder in reserve.

If the knob is not rotated before the empty cylinder is changed, two things can happen. First, gas may flow from the changed cylinder to the existing cylinder. This is because the pressure setting of the regulator on the primary side allows the regulator main valve to remain open. Second, when the cylinder is changed, gas will begin to flow from the new cylinder, stopping flow from the existing cylinder. This means the existing cylinder may be partially empty. After several cycles, it is possible that the reserve cylinder may empty shortly after a switchover occurs. Always remember to rotate the knob on the priority valve regulator **before** changing a depleted cylinder.

For models with pressure switches or transducers, a remote alarm can be used to provide an audible and visual warning that the need for a changeover is imminent. To maximize usage from your depleted bank of cylinders, wait until a changeover has actually occurred. The changeover may not coincide exactly with the alarm condition. You can tell that a changeover has actually occurred when you see a drop in the inlet pressure indicated on the inlet pressure gauge for the opposite side of the AutoSwitch.

The alarm set point can be adjusted on pressure switch models and transducer models. Adjusting the set point does not affect the switchover point of the AutoSwitch.

CAUTION

IMPORTANT:

DO NOT SET THE ALARM PRESSURE BELOW THE SYSTEM CHANGEOVER PRESSURE. Doing so will result in the alarm condition never being met, and the alarm will never be triggered.

For Pressure Switch Models:

Slide the red tab seen on each inlet gauge to adjust the alarm set point (see Figure 12). The lowering of the alarm set point pressure may cause the alarm to not work properly. When adjustments are made, check the function of the system. With the knob arrow turned fully clockwise, pressurize the system, and shut off the inlet pressure to both sides. Allow the inlet pressure on the right side to decrease by allowing a small flow (50 CFH). Observe both inlet gauges. When the right bank is low (below the set point on the gauge), the red LED will illuminate. Make sure the red LED illuminates before the pressure on the opposite side starts to decrease. Repressurize the system, and check the opposite side of the system in the same manner (the knob arrow must be turned fully counterclockwise).

For Transducer Models:

The alarm set point can be adjusted through the Altos 2 Remote Alarm. Refer to CONCOA instruction manual 9906 0025-24V (ADI 0025-24V).

Figure 12

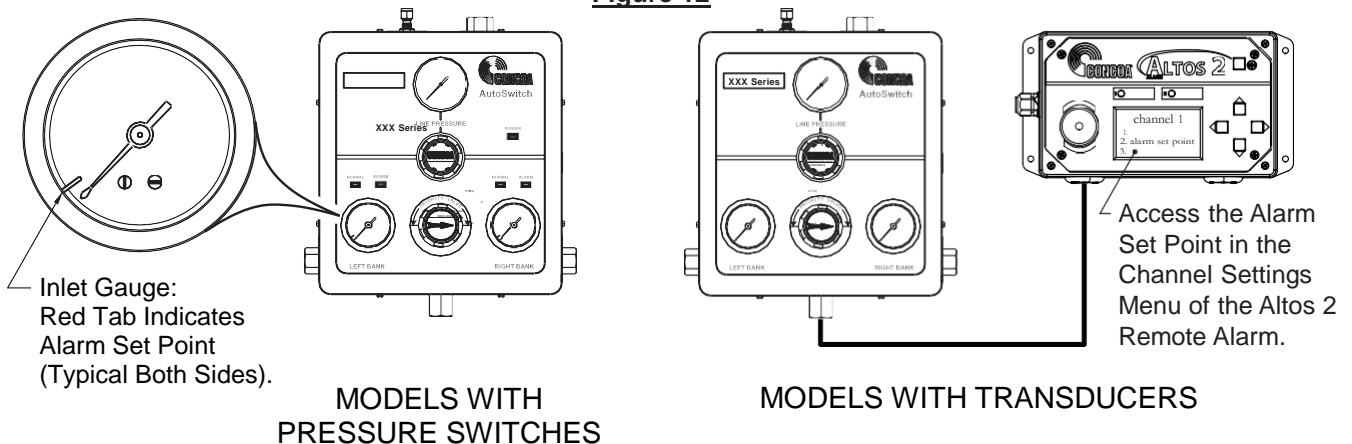

MAINTENANCE

At regular intervals, the system should be checked for leaks and proper function (see trouble shooting). Any leaks in the system should be corrected immediately. The hose check valve should also be checked for leaks when a depleted cylinder is removed. NOTE: the system inlet and hose should be pressurized when checking for leaks. At no time should the preset regulator or priority valve regulator factory settings be changed.

TROUBLESHOOTING

Symptom	Cause
<ol style="list-style-type: none"> 1. Gas leakage at the line regulator outlet when the adjusting knob of the line regulator is completely backed out. 2. With no flow through the system (downstream valve closed and adjusting screw in) line pressure steadily increases above set pressure. 3. Gas leakage from spring case (adjusting screw / knob end of regulator). 4. Gas leakage from any joint. 5. Excessive drop in working pressure with regulator flowing gas. 6. Gas leakage from relief valve. 7. Gas leakage from any gauge 8. Gauge does not return to zero when not under gas pressure 9. Gauge does not consistently repeat the same reading. 	<p>Regulator(s) have malfunctioned. Replace or repair</p>
<ol style="list-style-type: none"> 1. Switchover system seems to be using gas from the primary and reserve cylinders simultaneously (pressure is decreasing on both inlet gauges at the same time) 	<ol style="list-style-type: none"> 1. Make sure the priority valve knob is turned fully to the right or left. 2. Observe the inlet pressure. It may be necessary to do this during times of the heaviest use. If the inlet pressure is less than the values listed below, replace the high-pressure cylinders. <ul style="list-style-type: none"> 522 and 523 2XXX 265 PSI (18 BAR) 522 and 523 3XXX 265 PSI (18 BAR) 522 and 523 4XXX 345 PSI (24 BAR) 522 and 523 5XXX 540 PSI (37 BAR) 522 and 523 7XXX 265 PSI (18 BAR) <p>If liquid cylinders are used and the inlet pressure increases significantly when the system is not in use, then the system is over-withdrawing the liquid cylinders. Additional capacity may be added to the system to prevent this.</p> <p>NOTE: CONCOA does not recommend using liquid cylinders with the 522/523 Series AutoSwitches.</p>
<ol style="list-style-type: none"> 1. Inlet Gauges not reading pressure 	<ol style="list-style-type: none"> 1. Check that the valves on the cylinders are opened. 2. If using a manifold system, check that the valve on the manifold is opened.
<ol style="list-style-type: none"> 1. Power light is not on. (Pressure Switch Models Only) 	<ol style="list-style-type: none"> 1. Check that the remote alarm is powered on. 2. Check that the cable between the AutoSwitch and the remote alarm is wired correctly. 3. For models with a circular connector on the AutoSwitch, check that the cable connectors are properly plugged in at both ends.

TROUBLESHOOTING (cont.)

Symptom	Cause
1. Status lights are not lighted (Pressure Switch Models Only)	<ol style="list-style-type: none"> 1. Check that the remote alarm is powered on. 2. Check that the cable between the AutoSwitch and the remote alarm is wired correctly. 3. For models with a circular connector on the AutoSwitch, check that the cable connectors are properly plugged in at both ends.
<ol style="list-style-type: none"> 1. Green status light(s) are lighted when the pressure is below the set point on the gauges (Pressure Switch Models Only) 2. Red status light(s) are lighted when the pressure is above the set point on the gauges (Pressure Switch Models Only) 	<ol style="list-style-type: none"> 1. Cable to remote alarm wired incorrectly. Follow instructions in remote alarm instruction manual to correct problem.
1. With full tank pressure, red alarm light(s) are on. (Pressure Switch Models Only)	<ol style="list-style-type: none"> 1. Cable to remote alarm wired incorrectly. Follow instructions in remote alarm instruction manual to correct problem.
For status indication problems on transducer models, refer to the CONCOA Altos 2 Remote Alarm instruction manual 9906 0025-24V (ADI 0025-24V).	

SERVICE

A Unit that is not functioning properly should not be used and should be returned to CONCOA for service. A Return Material Authorization (RMA) number must be issued for any product returned to CONCOA for service. Please contact a Customer Service Representative at 1-800-225-0473 to receive this number. You will be asked to provide:

1. Model Number
2. Gas Service
3. Inlet pressure and type of gas supply
4. Outlet pressure
5. Approximate gas usage.

When shipping product back to CONCOA for repair, the following steps should be followed:

1. Package the product sufficiently to prevent damage. If possible, return product in its original packing.
2. Include RMA number on the outside of the carton.
3. Ship prepaid.
4. Include a written description of the problem you encountered with the product inside the package.
5. Include a statement of the gas service the product was used in.
6. Purge all equipment before shipping to protect the transporter and service personnel. Purging is especially important if the equipment has been in hazardous or corrosive gas service.

Warranty Information

This equipment is sold by CONTROLS CORPORATION OF AMERICA under the warranties set forth in the following paragraphs. Such warranties are extended only with respect to the purchase of this equipment directly from CONTROLS CORPORATION OF AMERICA or its Authorized Distributors as new merchandise and are extended to the first Buyer thereof other than for the purpose of resale.

For a period of one (1) year from the date of original delivery (90 days in corrosive service) to Buyer or to Buyer's order, this equipment is warranted to be free from functional defects in materials and workmanship and to conform to the description of this equipment contained in this manual and any accompanying labels and/or inserts, provided that the same is properly operated under conditions of normal use and that regular periodic maintenance and service is performed or replacements made in accordance with the instructions provided. The foregoing warranties shall not apply if the equipment has been repaired: other than by CONTROLS CORPORATION OF AMERICA or a designated service facility or in accordance with written instructions provided by CONTROLS CORPORATION OF AMERICA, or altered by anyone other than CONTROLS CORPORATION OF AMERICA, or if the equipment has been subject to abuse, misuse, negligence or accident.

CONTROLS CORPORATION OF AMERICA's sole and exclusive obligation and Buyer's sole and exclusive remedy under the above warranties is limited to repairing or replacing, free of charge, at CONTROLS CORPORATION OF AMERICA's option, the equipment or part, which is reported to its Authorized Distributor from whom purchased, and which if so advised, is returned with a statement of the observed deficiency, and proof of purchase of equipment or part not later than seven (7) days after the expiration date of the applicable warranty, to the nearest designated service facility during normal business hours, transportation charges prepaid, and which upon examination, is found not to comply with the above warranties. Return trip transportation charges for the equipment or part shall be paid by Buyer.

CONTROLS CORPORATION OF AMERICA SHALL NOT BE OTHERWISE LIABLE FOR ANY DAMAGES INCLUDING BUT NOT LIMITED TO: INCIDENTAL DAMAGES, CONSEQUENTIAL DAMAGES, OR SPECIAL DAMAGES, WHETHER SUCH DAMAGES RESULT FROM NEGLIGENCE, BREACH OF WARRANTY OR OTHERWISE.

THERE ARE NO EXPRESS OR IMPLIED WARRANTIES WHICH EXTEND BEYOND THE WARRANTIES HEREINABOVE SET FORTH. CONTROLS CORPORATION OF AMERICA MAKES NO WARRANTY OF MERCHANTABILITY OR FITNESS FOR A PARTICULAR PURPOSE WITH RESPECT TO THE EQUIPMENT OR PARTS THEREOF.



Controls Corporation of America
1501 Harpers Road Virginia Beach, VA 23454
Telephone 1-800-225-0473 or 757-422-8330 • Fax 757-422-3125
www.concoa.com