

ADI 3201-A



Laser Gas Station

INSTALLATION AND OPERATION INSTRUCTIONS

Before Installing or Operating, Read and Comply with These Instructions

Controls Corporation of America
1501 Harpers Road Virginia Beach, VA 23454
To Order Call 1-800-225-0473 or 757-422-8330 • Fax 757-422-3125
www.concoa.com

THIS PAGE INTENTIONALLY LEFT BLANK

DESCRIPTION OF PRODUCT

The Laser Gas Station is a wall mount system intended to mount any CONCOA high purity regulator to a wall. The flexible pigtail supplied with the system is intended to attach to a high pressure cylinder. The flexible pigtail has a check valve in the CGA connection to preclude the introduction of air into the pigtail during cylinder change.



Be absolutely certain of the gas service and cylinder pressure before connection to any high-pressure gas cylinder.

The Laser Gas Station block has a plugged port at the 3:00 position. The plug may be removed for the addition of a diaphragm valve for purging or for the installation of a second pigtail to connect two cylinders to the station.

INTENDED USE OF PRODUCT

The Laser Gas Stations are provided with 316L stainless steel core armor jacketed pigtails except for models intended for use with oxygen or oxidizing gases which are supplied with Monel core pigtails. It is the user's responsibility to determine the suitability of the materials of construction for his application. Please note the safety information shown in later section.

USER RESPONSIBILITY

This equipment will perform in conformity with the description contained in this manual and accompanying labels and/or inserts when installed, operated, maintained, and repaired in accordance with the instructions provided. This equipment must be checked periodically. Improperly working equipment should not be used. Parts that are broken, missing, worn, distorted or contaminated should be replaced immediately. CONCOA recommends that a telephone or written request for service advice be made to CONCOA Customer Service in Virginia Beach, Virginia.

This equipment or any of its parts should not be altered without consultation with an authorized CONCOA representative. The user of this equipment shall have the sole responsibility for any malfunction that results from improper use, faulty maintenance, damage, improper repair, or alteration by anyone other than CONCOA or a service facility designated by CONCOA.

Things to consider before removing the system from the box:

1. Know the properties and special handling requirements of the gas being used. Many specialty gases are quite dangerous (flammable, toxic, corrosive, simple asphyxiant, or oxidizers). Equipment failure or misuse may lead to problems such as a release of gas through the relief valve or regulator diaphragm. Proper safety measures should be established to handle these and other component failures.
2. Be sure that the assembly purchased is suitable for the gas and type of service intended. The regulator label provides the following information:
 - a) Model Number
 - b) Serial Number
 - c) Maximum Inlet Pressure

Be sure that the equipment received conforms to the order specifications. The user is responsible for selecting equipment compatible with the gas in use and conditions of pressure, temperature, flow, etc. Selection information can be found in CONCOA technical data sheets. In addition, CONCOA representatives are trained to aid in the selection process.
3. Inspect the assembly upon receipt to be sure that there is no damage or contamination. Pay particular attention to connecting threads. While CONCOA assembles system components to exacting leak-tight standards, the customer should also inspect for any loosening of parts that may occur in shipping or installation. Loose parts may be dangerously propelled from an assembly. If there are adverse signs (leakage or other malfunction), return the assembly to the supplier. While it is advised that soiled regulators be returned for cleaning, simple external dust or grease may be removed by a clean cloth and if required with aqueous detergent suitable for the application. If there are signs of internal contamination, return to the supplier.
4. Before system startup, it is recommended that all systems be pressure tested, leak tested, and purged with an inert gas such as nitrogen.

CUSTOMER ASSISTANCE

In the event of equipment failure, call the CONCOA Customer Assistance Line:

1-800-225-0473

Please be prepared to provide the model number and serial number of the equipment involved and some details regarding its application. This would include inlet and outlet pressures, flow rate, environmental conditions, and gas service.

GENERAL SAFETY PRACTICES



Comply with precautions listed in C.G.A. Pamphlet P-1, Safe Handling of Compressed Gases in Containers.

Consult the cylinder distributor for the proper use of cylinders and for any restrictions on their use (such as flow rate and temperature requirements).

Store cylinders with valve caps screwed on and cylinders chained to a supporting wall or column.

Handle cylinders carefully and only with valve caps screwed on. The cap will reduce the chance that the cylinder valve will break off if the cylinder is accidentally dropped or falls over. The cap also protects the cylinder valve from damage to screw threads which could cause leaky connections.

All manifolds used with flammable gases should be provided with approved flashback arrestors to stop any burning gas in the pipeline from getting back to the manifold or cylinders.

No smoking should be permitted near oxygen, nitrous oxide, any other oxidizer, flammable gases, or flammable mixtures, or in areas where cylinders are stored.

Where oxygen or nitrous oxide is used, the manifold and cylinders must be kept clean. No oil, grease, or combustible substances should come in contact with oxygen or nitrous oxide storage or handling equipment. Such materials in contact with oxygen or nitrous oxide are readily ignitable and, when ignited, will burn intensely.

Never use an open flame when leak testing.

Always open valves slowly when high-pressure gases are being used.

Always be sure that a cylinder contains the correct gas before connecting it to any manifold.

Always leak-test any manifold or distribution pipeline before using.

Always be sure that the gas in a pipeline is the correct gas for the intended use.

Always close all cylinder valves before disconnecting cylinders from a manifold.

Always remove **ALL** empty cylinders from a manifold before connecting full cylinders.

Always test cylinders to be sure the cylinders are **FULL** before connecting to a manifold.

General safety practices are continued on next page ...

General Safety Practices Continued



All gas distribution piping systems must meet the appropriate industrial standards for the intended service and must be thoroughly cleaned before using. For the United States, some applicable safety rules and precautions are listed below:

1. American National Standards Institute standard Z49.1, Safety in Welding and Cutting, American Welding Society, 2501 NW Seventh Street, Miami, Florida 33125
2. N.F.P.A. Standard 51, Oxygen-Fuel Gas systems for Welding and Cutting, N.F.P.A., 470 Atlantic Avenue, Boston, Massachusetts 02210
3. N.F.P.A. Standard 51B, Cutting and Welding Processes (same address as #2).
4. CONCOA publication ADE 872, Safety Precautions in Welding and Cutting.
5. Local Ordinances
6. O.S.H.A. Standard 29 CFR
7. C.G.A. Pamphlet C-4, American National Standard Method of Marking Portable Compressed Gas Containers to Identify the Material Contained.
8. C.G.A. Pamphlet G-4, Oxygen – Information on the properties, manufacture, transportation, storage, handling, and use of oxygen.
9. C.G.A. Pamphlet G-4.1, Equipment Cleaned for Oxygen Service.
10. C.G.A. Pamphlet G-4.4, Industrial Practices for Gaseous Oxygen Transmission and Distribution Piping Systems.
11. C.G.A. Pamphlet G-5, Hydrogen – Information on the properties, manufacture, transportation, storage, handling, and use of hydrogen.
12. C.G.A. Pamphlet G-6, Carbon Dioxide – Information on the properties, manufacture, transportation, storage, handling, and use of carbon dioxide.
13. C.G.A. Pamphlet G-6.1, Standard for Low Pressure Carbon Dioxide Systems at Consumer Sites.
14. C.G.A. Pamphlet P-1, Safe Handling of Compressed Gases in Containers.
15. C.G.A. Safety Bulletin SB-2, Oxygen Deficient Atmospheres.

*C.G.A. pamphlets can be obtained from:

Compressed Gas Association
1235 Jefferson Davis Highway
Arlington, VA 22202-3239
(703) 979-0900
Publications: (703) 979-4341. Fax: (703) 979-0134.

LOCATION

Keep all cylinders away from any source of high temperature over 120°F (50°C) or possible fire hazards. High-pressure gas contained in a closed cylinder becomes increasingly dangerous when exposed to high temperature because pressure increases and the strength of the cylinder decreases.

Cylinders installed in open locations should be protected from weather conditions. During winter, protect the cylinders from ice and snow. In summer, shade the cylinders from continuous exposure to direct sunlight.

Always leave access to the cylinder for cylinder replacement.

GENERAL INSTALLATION AND OPERATION

Installing Inlet and Outlet Connections:

CONCOA uses PTFE tape on all of its regulator NPT connections.

Follow these rules when using PTFE tape:

Inspect the NPT threads and, if necessary, clean the fitting to remove any dirt or thread sealant that remains on the threads. Start the PTFE tape on the second thread as shown in Figure 1. Make sure the tape does not overlap the end of the fitting. As the tape is wrapped in the direction of the thread spiral, pull tightly on the end of tape so that the tape conforms to the threads. Wrap the tape around the threads twice. Cut off the excess tape, and press the end firmly into the threads.

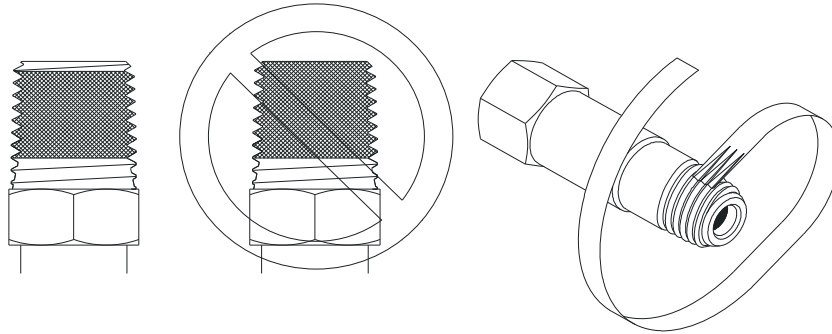

Figure 1 – Pictorial View of Tape Seal

Installation and Operation:



1. The Laser Gas Station shall be securely fastened to a wall using fasteners appropriate for the wall construction. Mounting dimensions are provided in Figure 2 and 3.
2. If not already installed, the pigtail provided shall be threaded into the inlet connection on the protocol tee as described in the section "Installing Inlet and Outlet Connections".
3. Secure the cylinder to the wall using a cylinder wall bracket, CONCOA part number 518-1611
4. Thread the cylinder connection to the cylinder. Assure that the CGA connection on the pigtail is appropriate for the gas service and matches the valve on the cylinder.
5. Before operating the regulator, read and understand ADI-2068, Regulator Installation and Operation Instructions.

Mounting Dimensions:

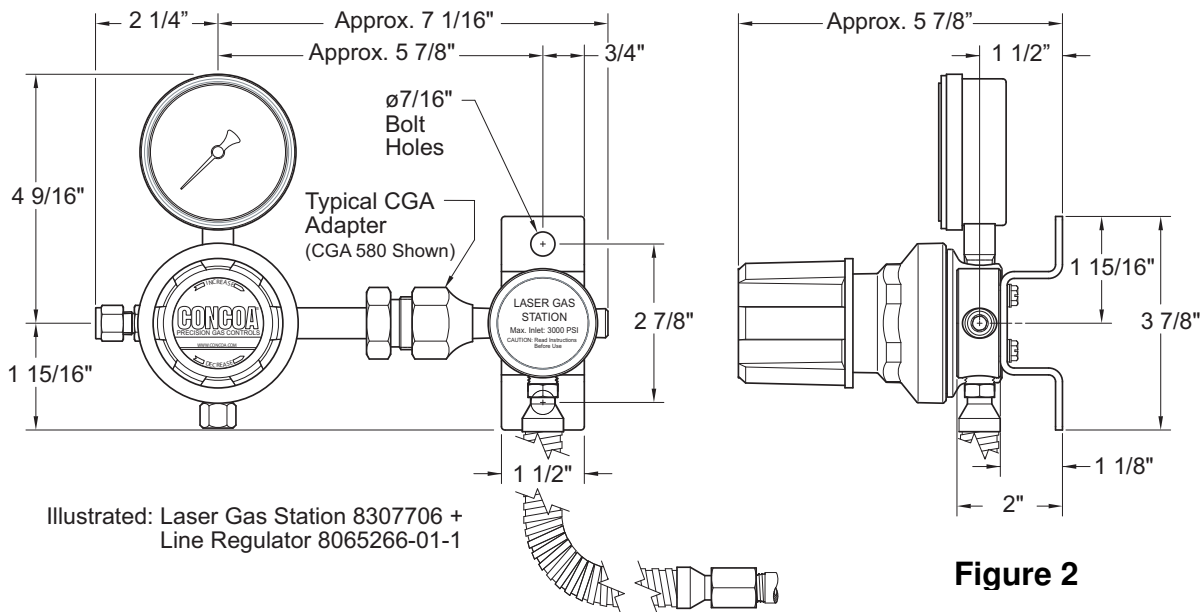

Figure 2

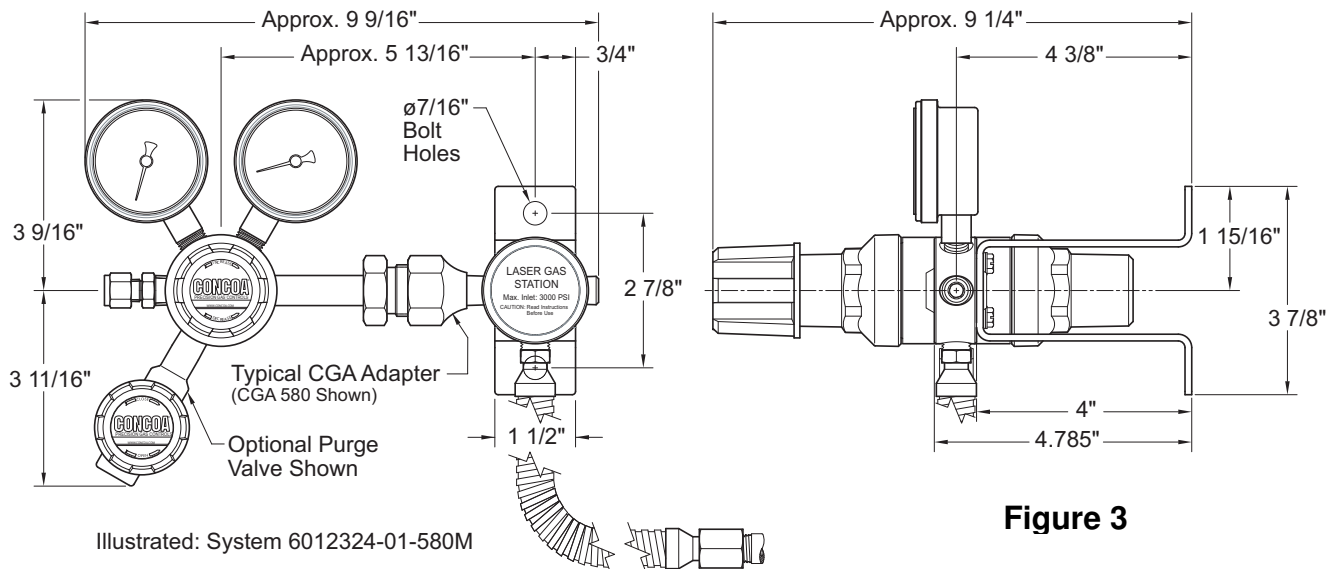

Figure 3

Connecting to a Cylinder



1. Before removing the cylinder cap, move the cylinder of gas to the work site:
 - a. Secure cylinder to the floor, wall, or bench with appropriate chain, strap, or stand to prevent toppling.
 - b. Remove the cylinder cap.
 - c. Be sure the cylinder valve is tightly closed (clockwise).
 - d. Remove the cylinder valve plug, if any.
 - e. Inspect the cylinder valve and threads for damage or contamination.
2. Secure the cylinder connection to the cylinder in the following manner:
 - a. Do not force. Tightening the nut onto the cylinder connection should be easy. If it is not, the connection may be wrong for the type of gas being used.
 - b. Left-hand threads are used on some cylinder connections. A notch in the middle of the hex nut typically indicates a left-hand thread.
 - c. Gaskets are used on some inlet connections. Be sure the gasket is in good shape. Do not over-tighten to avoid squashing the gasket into the gas line. Keep extra gaskets on hand.
 - d. Never use oil or grease on regulator or cylinder fittings as it may contaminate pure gases or create a fire hazard.

Pressurizing the system for the first time:

Before system startup, it is recommended that all systems be pressure tested, leak tested, and purged with an inert gas such as nitrogen.

1. Wear safety glasses and gloves.
2. Be sure that both ends of all hoses or pigtailed are secured before pressurizing.
3. When first pressurizing, do not stand in front of or contact the Protocol Station or regulator. Slowly open the cylinder valve. Observe the high pressure gauge on the regulator (if available) for a rise in pressure up to full cylinder pressure.
4. Keep the hand wheel or wrench on the open cylinder valve at all times to allow prompt emergency shut-off.
5. Inspect all connections for leaks and fix any leaks. A leak detection solution may be applied to the connections (if compatible with the application) which indicates leaks by bubbling. To further check for leaks, or if the leak detection solution cannot be used, close the cylinder valve for a period of time (recommended 24 hours), and observe the high pressure gauge for a drop in pressure. If so indicated, recheck the CGA connection and all other high-pressure port connections.

 **Never attempt to fix a leak under pressure.**

If leaks are detected, depressurize the system, and retighten the connection. Begin again at step 3.

DISCONNECTING A DEPLETED CYLINDER

Before disconnecting a cylinder from the Laser Gas Station, assure that the cylinder valve is closed (turned fully clockwise). Check the high pressure gauge on the pressure regulator to assure that the pressure in the pigtail is below 200 psig. The pigtail has a check valve in the CGA connection to prevent back flow of gas from the system and to prevent the entry of air when the pigtail is disconnected. Therefore, the pigtail will be pressurized when disconnected.

 **Never disconnect a pigtail under full cylinder pressure.**

If it is ever necessary to disconnect a full cylinder, close the cylinder valve, and bleed pressure through the regulator before removing the CGA connection.

MAINTENANCE

On regular intervals, the system should be checked for leaks and proper function. Any leaks in the system should be corrected immediately. The pigtail check valve should also be checked for leaks when a depleted cylinder is removed.

Note: The system inlet and pigtail should be pressurized when checking for leaks.

SERVICE

A unit that is not functioning properly should not be used. It is recommended that all servicing be done by a service facility authorized by CONCOA. Contact the CONCOA Warranty Administrator in Virginia Beach, Virginia for systems still covered by the warranty. For items not covered by the warranty, contact the nearest CONCOA District Sales Office for assistance.

If so advised, the unit should be sent to a service facility authorized by CONCOA. Do the following before shipping:

1. Adequately package the system. If possible package in the original shipping container.
2. Ship prepaid.
3. Include a statement of the observed deficiency.
4. Indicate the gas service that the equipment was used on.
5. Purge all equipment before shipment to protect the transporter and service personnel. The purging is especially important if the equipment has been in hazardous or corrosive gas service.

Warranty Information

This equipment is sold by CONTROLS CORPORATION OF AMERICA under the warranties set forth in the following paragraphs. Such warranties are extended only with respect to the purchase of this equipment directly from CONTROLS CORPORATION OF AMERICA or its Authorized Distributors as new merchandise and are extended to the first Buyer thereof other than for the purpose of resale.

For a period of one (1) year from the date of original delivery (90 days in corrosive service) to Buyer or to Buyer's order, this equipment is warranted to be free from functional defects in materials and workmanship and to conform to the description of this equipment contained in this manual and any accompanying labels and/or inserts, provided that the same is properly operated under conditions of normal use and that regular periodic maintenance and service is performed or replacements made in accordance with the instructions provided. The foregoing warranties shall not apply if the equipment has been repaired: other than by CONTROLS CORPORATION OF AMERICA or a designated service facility or in accordance with written instructions provided by CONTROLS CORPORATION OF AMERICA, or altered by anyone other than CONTROLS CORPORATION OF AMERICA, or if the equipment has been subject to abuse, misuse, negligence or accident.

CONTROLS CORPORATION OF AMERICA's sole and exclusive obligation and Buyer's sole and exclusive remedy under the above warranties is limited to repairing or replacing, free of charge, at CONTROLS CORPORATION OF AMERICA's option, the equipment or part, which is reported to its Authorized Distributor from whom purchased, and which if so advised, is returned with a statement of the observed deficiency, and proof of purchase of equipment or part not later than seven (7) days after the expiration date of the applicable warranty, to the nearest designated service facility during normal business hours, transportation charges prepaid, and which upon examination, is found not to comply with the above warranties. Return trip transportation charges for the equipment or part shall be paid by Buyer.

CONTROLS CORPORATION OF AMERICA SHALL NOT BE OTHERWISE LIABLE FOR ANY DAMAGES INCLUDING BUT NOT LIMITED TO: INCIDENTAL DAMAGES, CONSEQUENTIAL DAMAGES, OR SPECIAL DAMAGES, WHETHER SUCH DAMAGES RESULT FROM NEGLIGENCE, BREACH OF WARRANTY OR OTHERWISE.

THERE ARE NO EXPRESS OR IMPLIED WARRANTIES WHICH EXTEND BEYOND THE WARRANTIES HEREINABOVE SET FORTH. CONTROLS CORPORATION OF AMERICA MAKES NO WARRANTY OF MERCHANTABILITY OR FITNESS FOR A PARTICULAR PURPOSE WITH RESPECT TO THE EQUIPMENT OR PARTS THEREOF.

ADI 3201-A



Controls Corporation of America
1501 Harpers Road Virginia Beach, VA 23454
To Order Call 1-800-225-0473 or 757-422-8330 • Fax 757-422-3125
www.concoa.com