

GAS BLENDING SYSTEMS



652 SERIES BLENDMASTER 1000

The BlendMaster 1000 Series mixer precisely blends binary mixtures for the metal fabrication industry. Carbon Dioxide and Helium minor component mixes are consistently delivered to those industrial applications requiring repeatability and control. Available in wall or floor mount and 120 volt or 220 volt configuration, the BlendMaster 1000 delivers the flexibility that yields a low cost of ownership.

Advanced Features

Pressure Equalization Technology

Maintains mix accuracy under fluctuating supply conditions

0-100% Ratio Adjustment

Ensures 1,000 SCFH for all mixes

Gas Piloted Dual-Dome Technology

Maintains mix accuracy by eliminating pressure decay at high-flows

6700 Series Line Regulator

Delivers stable pressure control at high-flows

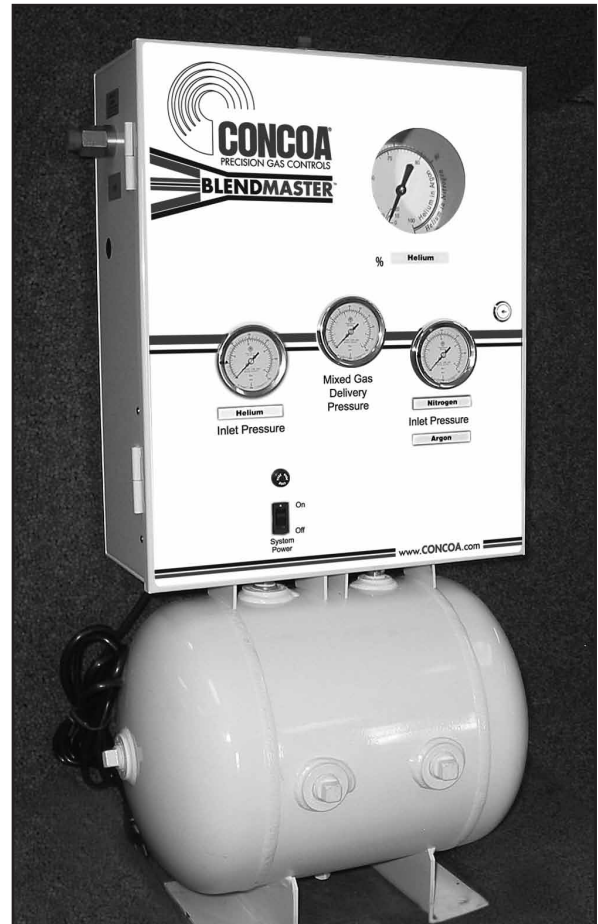

Applications

Laser Welding

25-50% Argon, balance Helium
Enables higher travel speeds

GMAW (MIG) Welding

0-10% Carbon Dioxide Mild Steel
Deep penetrating spray transfer
15-25% Carbon Dioxide Mild Steel
Spatter-free short arc transfer

Materials

Case

Powder-coated steel

Surge Tank

Powder-coated steel

Regulator

Brass barstock

Seals

Neoprene

40-Micron Inlet Filter

316L stainless steel

Inlet and Outlet Fittings

Brass

Specifications

Flow Capacity

1000 SCFH (28.3 M³/H)

Inlet Supply Pressure Requirements

100 - 125 PSIG (7 - 8.6 BAR)

Mixed Gas Outlet Pressure

10 - 50 PSIG (.7 - 3.5 BAR)

Power Requirements

110 or 220 VAC (50 - 60 Hz)

Temperature Range

32°F to 100°F (0°C to 38°C)

Accuracy

± 1.5%

Weight

102 lbs. (46 kg)

Surge Tank

7 gallon (26.5 liters)

GAS BLENDING SYSTEMS



Installation Dimensions

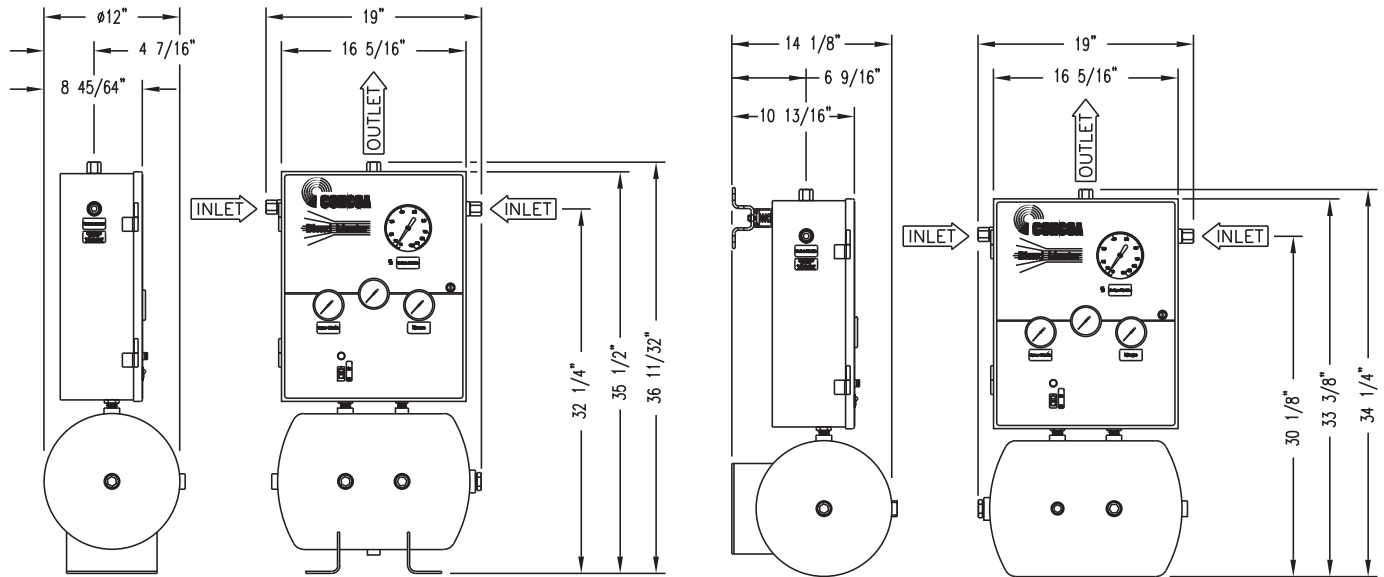

Floor-Mounted

Wall-Mounted

Ordering Information

Series	Major Gas	Minor Gas	Monitoring*	Assembly	Secondary Scale Major Gas	Secondary Scale Minor Gas
652	1: Argon	1: Argon	0: No Alarm	1: 110V Floor Mount	0: None	0: None
	5: Nitrogen	2: Carbon Dioxide	7: Low Pressure Alarm Capable*	2: 110V Wall Mount	1: Argon	1: Argon
		3: Helium		5: 220V Floor Mount	5: Nitrogen	2: Carbon Dioxide
		5: Nitrogen		6: 220V Wall Mount		3: Helium
					5: Nitrogen	
			* Remote alarm not included			

Related Options

Part Number	Option	Description
575 0025-01-000	Altos 2 Alarm	Provides real-time cylinder pressure, audible and visual notification of a depleted supply bank to a remote location. (See page 46 for full list of options)