

GAS BLENDING SYSTEMS



655 SERIES OXYGEN BLENDMASTER

The 655 Series BlendMaster is designed to supply Argon-Oxygen shielding gas mixtures on-site for mild and stainless steel MIG (GMAW) welding. The blender provides up to 850 SCFH over the range of 0-10% Oxygen, balance Argon. CONCOA 6700 Series inlet regulators maintain mix accuracy by eliminating pressure fluctuation effects encountered while filling micro-bulk and bulk supply sources.

Advanced Features

Lockable Enclosure

Process control

0-10% Ratio Adjustability

Process flexibility

Wall or Bench Mountable

Installation flexibility

Integral Line Regulator

Supports flowmeter and regulator/flowmeter installations

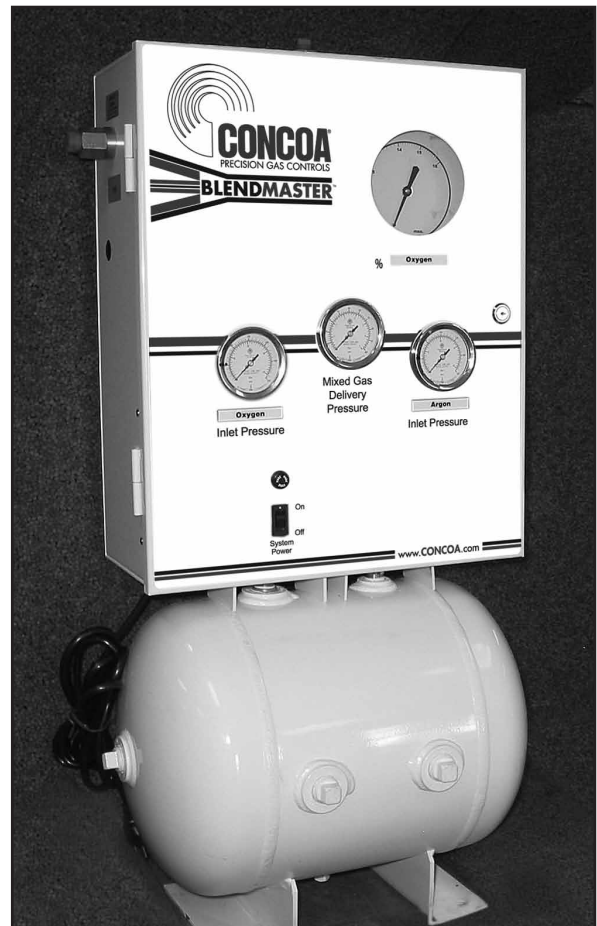

Applications

Stainless Steel

0-1% Oxygen
Stabilized spray transfer

1-2% Oxygen
Spray transfer with enhanced wetting action

Mild Steel

2-3% Oxygen
Spray transfer with enhanced wetting action

3-5% Oxygen
High travel speeds with fluid weld puddle

Materials

Case

Powder-coated steel

Surge Tank

Powder-coated steel

Regulator

Brass barstock

Seals

Neoprene

40-Micron Inlet Filter

316L stainless steel

Inlet and Outlet Fittings

Brass

Specifications

Flow Capacity

850 SCFH (24.1 M³/H)

Inlet Supply Pressure Requirements

100 - 125 PSIG (7 - 8.6 BAR)

Mixed Gas Outlet Pressure

10 - 50 PSIG (.7 - 3.5 BAR)

Power Requirements

110 or 220 VAC (50 - 60 Hz)

Temperature Range

32°F to 100°F (0°C to 38°C)

Accuracy

± 0.5%

Weight

102 lbs. (46 kg)

Surge Tank

7 gallon (26.5 liters)

GAS BLENDING SYSTEMS



Installation Dimensions

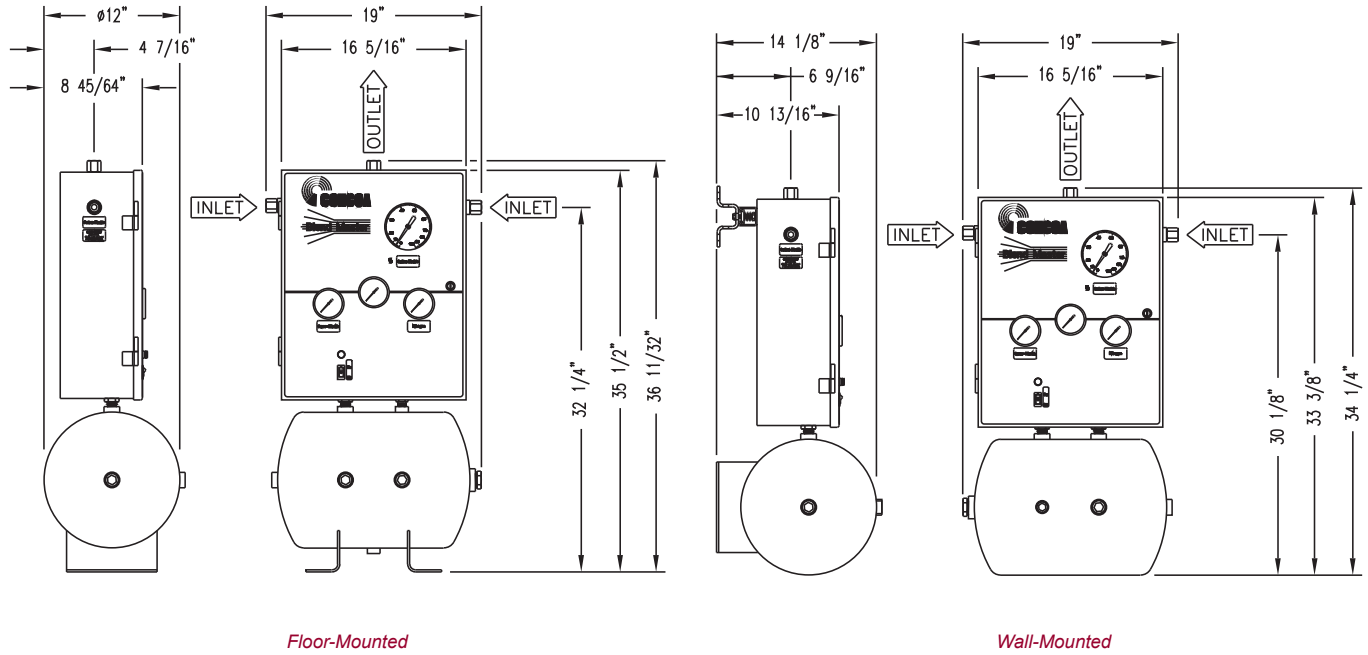

Ordering Information

Series	Major Gas	Minor Gas	Monitoring*	Assembly
655	1: Argon	1: Oxygen	0: No Alarm	1: 110V Floor Mount
			7: Low Pressure Alarm Capability*	2: 110V Wall Mount
				5: 220V Floor Mount
				6: 220V Wall Mount
* Remote alarm not included				

Related Options

Part Number	Option	Description
575 0025-01-000	Altos 2 Alarm	Provides real-time cylinder pressure, audible and visual notification of a depleted supply bank to a remote location. (See page 46 for full list of options)