

619 SERIES Resonator Gas Supply

619 SERIES SWITCHOVER

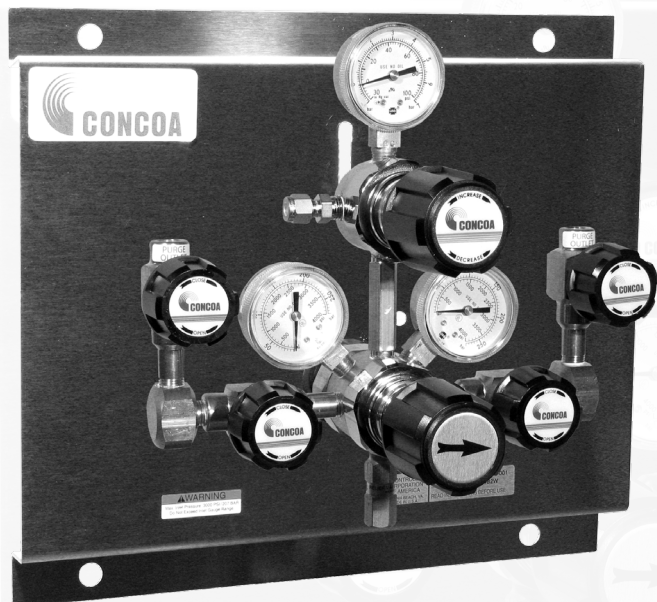

The 619 Series is an automatic pressure differential switchover that delivers a continuous supply of resonator gas without compromising purity. Low internal volume coupled with an optional inlet micro-purge virtually eliminates gas contamination. In addition, the stainless steel diaphragms and double seal relief valve enable the 619 to achieve 1×10^{-8} He scc/sec leak integrity.

Advanced Features

MACHINED BRASS BARSTOCK BODY	Smooth surface finish
LOW WETTED SURFACE AREA	Minimal purge requirements
CONVOLUTED 316L DIAPHRAGM	No inboard diffusion
OPTIONAL MICRO-PURGE	Low dead volume space
INTERNAL 10-MICRON FILTRATION	Eliminates common regulator failure
METAL TO METAL SEALS	No leaks
DOUBLE SEAL RELIEF	No permeation
OPTIONAL INTEGRAL MICRO MANIFOLD	Accommodates up to 3 cylinders per side

6192201-01-001M shown

Applications	Materials	Specifications
Laser Pure Resonator Gases Helium Nitrogen Carbon Dioxide	Body Machined brass barstock Bonnet Chrome plated brass barstock	Maximum Inlet Pressure 3000 PSIG (210 BAR) 4500 PSIG (310 BAR) Temperature Range -40°F to 140°F (-40°C to 60°C)
Laser Mixed Resonator Gases Three gas premix Four gas premix Five gas premix	Seat PTFE PCTFE	Gauges 2" (50mm) diameter BAR/PSIG
Laser Purging Gases Zero Air Nitrogen	Filter 10-micron sintered bronze Diaphragm 316L stainless steel	Inlet Connection 1/4" FPT Helium Leak Integrity 1×10^{-8} scc/sec CV 0.1 Weight 8.25 lbs. (3.71 kg)

Resonator

Gas Supply

619 SERIES

Resonator Gas Supply

Flow Performance Curves

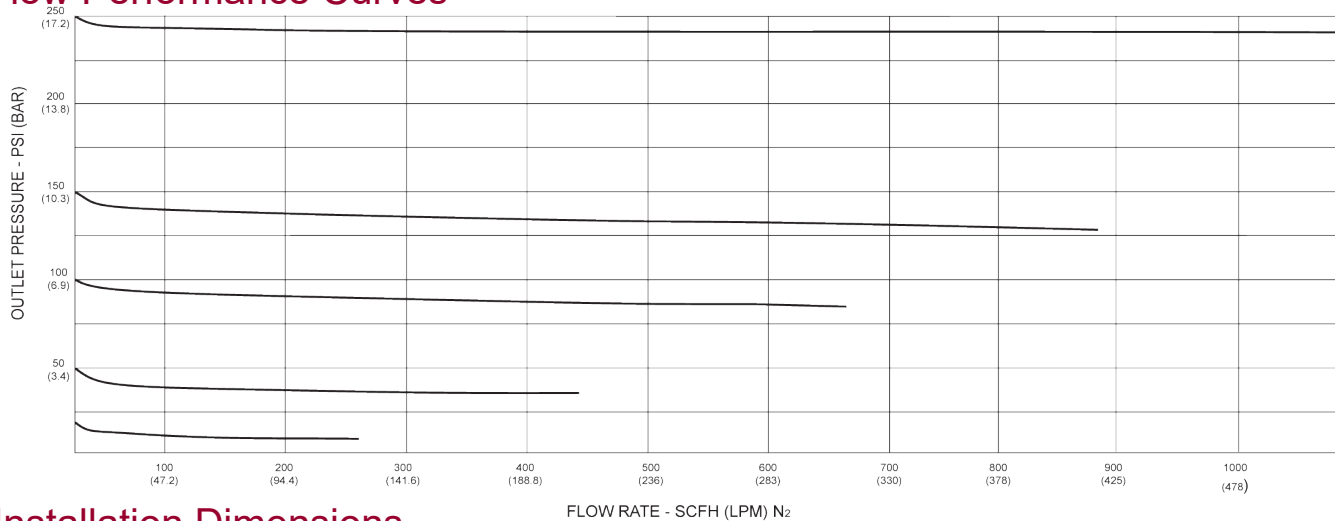

Installation Dimensions

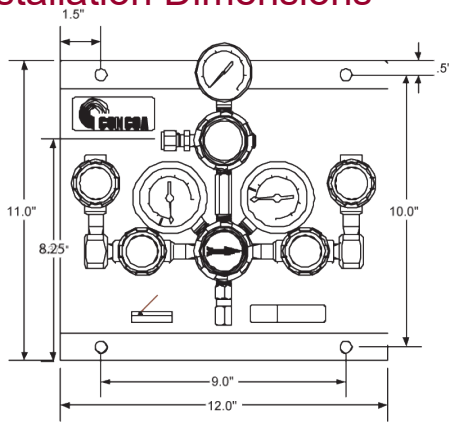

Ordering Information

619 Series	A	B	C	D	CON	Options
619	Max Delivery Pressure	Inlet Connection	Cylinders Per Side	Assembly/Gauges	Inlet	Installed Options
	2: 50 PSIG (3.4 BAR)	0: 1/4" FPT port	0: 1 Cylinder (1/4" FPT inlet)	1: Line Regulator 3000 PSIG (210 BAR) without Alarm Capability	001: 1/4" FPT Please specify inlet connection	M: 6mm tube fitting outlet
	3: 100 PSIG (7 BAR)	1: Diaphragm valve (with 1/4" FPT inlet port)	1: 1 Cylinder (36" hose)	4: Line Regulator 3000 PSIG (210 BAR) with Alarm Capability		
	4: 200 PSIG (14 BAR)	2: Micro-Manifold and Purge (with 1/4" FPT inlet port)	2: 2 Cylinders (36" hoses)	5: Line Regulator 4500 PSIG (210 BAR) without Alarm Capability		
			C: 1 Cylinder (72" hose)	8: Line Regulator 4500 PSIG (210 BAR) with Alarm Capability		
			D: 2 Cylinders (72" hoses)			

Available Options

Option	Part No.	Description
Advantium 8	5295310-01-001 (110 Volt) 5295311-01-001 (220 Volt)	Remote alarm for up to four 619 switchovers, featuring audible and visual alarm at remote unit, RS-232 computer interface, and optional telephone dialers.
Advantium 2	5750023-01-000 (110/220 Volt)	Remote alarm (universal input) provides audible remote alarm for a single 619 switchover.
Single Switchover Stand	5181625	Appropriate support for a single switchover with one cylinder per side.
Multi Switchover Stand	5181725	Appropriate support for three switchovers with one cylinder per side.