

Lab Safety Equipment



580 SERIES

Horn and Strobe

The 580 Series Horn and Strobe is PLC compatible and designed for use with any CONCOA air safety monitor, gas detector, or emergency shut-off controller. Available with red, amber, or blue LED dome light, the bright xenon strobe and warning horn provide a synchronized visual and audible signal when remotely activated. CONCOA horn and strobe is typically mounted above a doorway or entrance of the space being monitored and is a critical component of a fully integrated, comprehensive facility safety system.



Specifications

Material	ABS Plastic Body with Polycarbonate Lens
Operating Voltage	68mA @ 18-30 VDC
Lamp Life	10,000 hours
Light Source	Xenon Strobe Tube
Strobe Frequency	60 Flashes per Minute (FPM)
Decibal Range	82-100 dBa @ 10 ft (92-110 dBa @ 1 m)
Operating Temperature	14°F to 131°F (-10°C to 55°C)
Enclosure Rating	IP54
Conformances	CE Marked; RoHS Compliant

Installation Dimensions

Low Profile Sounder Strobe

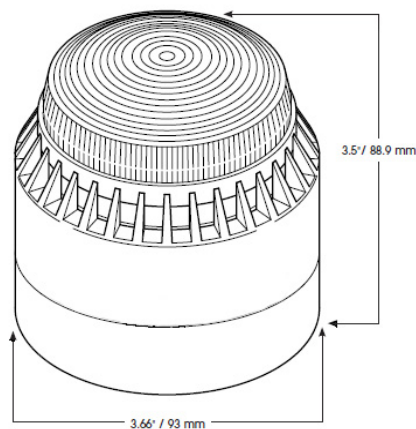

Ordering Information

Order No.	Description
580 3006	Horn and Strobe Combo, Red LED
580 3006-A	Horn and Strobe Combo, Amber LED
580 3006-B	Horn and Strobe Combo, Blue LED